

Plutonium Disposition Study Options Independent Assessment Phase 2 Report

August 20, 2015

Matthew J. Hart¹, Nichols F. Brown², Mark J. Rokey¹, Harold J. Huslage³, J. Denise Castro-Bran⁴, Norman Y. Lao⁵, Roland J. Duphily⁵, Vincent M. Canales², Joshua P. Davis⁶, Whitney L. Plumb-Starnes⁷, Jya-Syin W. Chien⁵

¹Civil Applications Directorate, Civil and Commercial Programs Division

²Schedule and Cost Analysis Department, Acquisition Analysis and Planning Subdivision

³Nuclear Security Programs, Civil Applications Directorate

⁴Systems and Operations Assurance Department, Mission Assurance Subdivision

⁵Acquisition Risk and Reliability Engineering Department, Mission Assurance Subdivision

⁶Vehicle Conceptual Design Section, Architecture and Design Subdivision

⁷Systems Performance Estimation and Algorithms Department, Architecture and Design Subdivision

Prepared for:

National Nuclear Security Administration
1000 Independence Avenue S.W.
Washington, DC 20585

Contract No. FA8802-14-C-0001

Authorized by: Civil and Commercial Programs Division

Distribution Statement B: Distribution authorized to U.S. Government agencies; Administrative or Operational Use. August 20, 2015. Other requests for this document shall be referred to NNSA/NA-23.

Destruction Notice: For classified documents, follow the procedures in DOD 5200.22-M, Industrial Security Manual, Section 11-19 or DOD 5200.1-R, Information Security Program Regulation, Chapter IX. For unclassified, limited documents, destroy by any method that will prevent disclosure of the contents or reconstruction of the document.

Contents

1. Review Charter.....3

2. Executive Summary4

3. Assessment Methodology8

 3.1 Data Sources.....8

 3.2 Assessment Areas.....8

4. Option 1: MOX Fuel Program10

 4.1 Project Complexity.....11

 4.2 Program Dependencies.....11

 4.3 Technology Drivers.....12

 4.4 Basis of Estimate.....12

 4.5 Other Factors.....13

5. Option 2: Advanced Disposition Reactor16

 5.1 Project Complexity.....16

 5.2 Program Dependencies.....17

 5.3 Technology Drivers.....18

 5.4 Basis of Estimate.....19

 5.5 Other Factors.....20

6. Option 3: Immobilization Program21

 6.1 Project Complexity.....21

 6.2 Program Dependencies.....22

 6.3 Technology Drivers.....23

 6.4 Basis of Estimate.....23

 6.5 Other Factors.....24

7. Option 4: Downblend Program26

 7.1 Project Complexity.....26

 7.2 Program Dependencies.....27

 7.3 Technology Drivers.....27

 7.4 Basis of Estimate.....27

 7.5 Other Factors.....28

8. Option 5: Borehole.....30

 8.1 Project Complexity.....30

 8.2 Program Dependencies.....31

 8.3 Technology Drivers.....31

 8.4 Basis of Estimate.....32

 8.5 Other Factors.....33

9. Common Program Dependencies Impacting Cost and Schedule.....34

10. Key Observations35

11. Assessment of 2014 PWG Report.....41

Appendix A: Bibliography44

Appendix B: Acronyms.....45

Figures

Figure 1. MOX Fuel Program Workflow 10
Figure 2. ADR Program Workflow 16
Figure 3. Immobilization Program Workflow 21
Figure 4. Downblend Program Workflow 26
Figure 5. Borehole Program Workflow 30

Tables

Table 1 Key Point Summary 40

1. Review Charter

As part of its mission to reduce global danger from weapons of mass destruction, the Defense Nuclear Nonproliferation Program, sponsored by the National Nuclear Security Administration's Office of Material Management and Minimization, is responsible for the implementation of the U.S.-Russia Plutonium Management and Disposition Agreement (PMDA).

The PMDA commits United States and Russia to each dispose of at least 34 metric tons (MT) of weapon-grade plutonium. In 2013, the Secretary of Energy formed the Plutonium Disposition Working Group (PWG) to examine options to complete the U.S. plutonium disposition mission. The PWG released its findings in its "Report of the Plutonium Disposition Working Group: Analysis of Surplus Weapon-Grade Plutonium Disposition Options" in April 2014, with assessment of five plutonium disposal options:

1. Conversion of plutonium to a mixed oxide (MOX) fuel for use in commercial reactors (currently the official Program of Record)
2. Irradiation of plutonium in fast reactors
3. Immobilization of plutonium with high level waste
4. Downblending of plutonium with an inert material and disposal in a geologic repository
5. Disposal of plutonium in a deep borehole

Following the release of the PWG report, Congress directed NNSA to engage a Federally Funded Research and Development Center (FFRDC) to conduct an independent review of the report's analyses and findings. In December 2014, NNSA contracted with The Aerospace Corporation ("Aerospace") to perform this review. For each of the five options, Aerospace was asked to assess and validate the report's analysis and findings, independently review the cost estimating basis of estimate, and perform an assessment of technical and programmatic factors impacting cost and schedule, such as technical uncertainty and risk, certification of new facilities and technologies, disposal execution processes and documentation, compliance with environmental regulations and governance agencies external to DOE, and regulatory and public acceptance issues and interactions with affected States.

This Phase 2 report addresses the review of Options 2, 3, and 5. It also incorporates information from the Phase 1 report, which reviewed Options 1 and 4 and is documented in "Plutonium Disposition Study Options Independent Assessment Phase 1 Report, Option 1: MOX Fuel, Option 4: Downblend", April 13, 2015, TOR-2015-01848.

The Aerospace Corporation maintains professional expertise and analytic capabilities in facilities architecture and design, civil, structural, mechanical, and electrical engineering, and independent technical, schedule, and cost risk assessments for large-scale complex systems. This experience is routinely applied across the entire life cycle of concept development, planning, cost estimation, design, construction and operations for long-term missions in a variety of civil, commercial, and national security application domains.

2. Executive Summary

To conduct its independent review, Aerospace assembled a team of engineers and analysts with experience in facilities engineering and development, program cost and schedule assessment, technical and programmatic risk analysis, nuclear power industry facilities and operations, and the nation's nuclear weapons complex. The Aerospace team reviewed the full 2014 PWG report and other documentation provided by NNSA, and participated in discussions, presentations and facility tours related to each of the plutonium disposition options.

In conducting the assessment, Aerospace was asked to 1) independently assess the 2014 PWG report's basis of cost estimates, 2) identify technical and programmatic factors bearing on the cost and schedule estimates, and 3) provide an overall assessment of the 2014 PWG report's findings.

Aerospace considered a number of assessment areas in order to identify factors that discriminate between the options and capture other relevant information not captured in the 2014 PWG report. Assessment areas included Project Complexity, which addresses intricacy of design and coordination of activities necessary for each option; Program Dependencies, which addresses the extent to which resources outside the project are required; Technology Drivers, which address needed new technology developments; Basis of Estimate, which addresses the pedigree of the basis of estimate for the costs reported in the 2014 PWG report, and Other Factors, which address certification, regulatory, governance and state and local issues.

Section 3 of this report provides a description of the assessment approach. Section 4-8 provides a high level description of each of the five options discussion and key discriminators in each of the assessment areas described above. Section 9 discusses technical and programmatic factors impacting all options. Section 10 provides a summary of key points from the Aerospace assessment, and Section 11 provides a comparative assessment the 2014 PWG report findings relative to the observations herein.

Aerospace did not assess the scientific and technical aspects of the physics, chemistry, and metallurgy processes used in these options. Aerospace did not assess the adequacy of the existing and proposed facilities to support the physics, chemistry, and metallurgy processes used in these options. Aerospace did not conduct an independent grass-roots, parametric, or analogy-based cost estimate on these options.

Key observations from this assessment are generally consistent with the 2014 PWG Report's discussion in areas of *Technical Viability*, *International Commitments*, and *Other Factors* but differ in areas of *Cost-to-go and Completion Timelines*. Comparison of the key observations between the 2014 PWG Report and this assessment are summarized by option below:

Option 1 MOX Fuel

Both the Aerospace independent assessment and the 2014 PWG report acknowledge that the MOX Fuel option meets current PMDA requirements. Both assessments acknowledge that the MOX Fuel project is technically and programmatically complex with significant risk associated with the completion of construction and facility startup. Both reports note uncertainties associated with the NRC licensing process, facility certification, fuel qualification, and participation by the commercial nuclear power industry in completing the disposition mission, each of which introduces risk into the program. Both assessments note the challenges in maintaining workforce and suppliers with the requisite experience in nuclear facilities, systems, and operations.

Predecisional - Official Use Only

The Aerospace report cites additional programmatic risk associated with overall program integration of key program element interfaces and dependencies between feedstock production, MOX Fuel production, participation by the commercial nuclear power industry, and uncertainties in operations and production rates.

Aerospace assesses the basis of estimate of the MOX Fuel program cost-to-go to be adequate for concept level costing and consistent with industry best practices. However the 2014 PWG report cost estimate is low relative to what may be realized at completion of construction and operations, due primarily to the absence of consideration for programmatic risk associated with the program element interdependencies and the impacts of annual funding constraints on MFFF construction (see the companion report, "Plutonium Disposition Study Options Independent Assessment Phase 1 Report, Option 1: MOX Fuel, Option 4: Downblend," April 13, 2015, TOR-2015-01848).

Option 2 Advanced Disposition Reactor (ADR)

Both reports acknowledge that changes will be required to the PMDA to accommodate the ADR option. Both reports acknowledge the high technical and programmatic risks inherent in the necessary research and development, technology demonstration, full-scale design, construction, and startup of an advanced fast spectrum burner sodium cooled reactor. Both reports acknowledge that additional new facilities for metal fabrication will be required, incurring additional technical and programmatic risk. It is expected in both reports that the NRC licensing process and fuel qualification process will be lengthy.

ADR is the most complex and technically challenging option. The Aerospace assessment notes significant issues with the industrial base, including the adequacy of the workforce, fast reactor knowledge base, and the need for a significant R&D and technology development and demonstration phase prior to reaching CD-2. Long term storage of spent plutonium metal fuel rods may require a different approach than that used for spent commercial uranium fuel rods, and may require the development of a new facility. As with the MOX Fuel option, the Aerospace assessment cites additional programmatic risk associated with interface management between fuel production, ADR power generation, and the electric power grid.

Aerospace finds the quality and completeness of the cost basis of estimate is difficult to assess due to the age of the source data provided, but it is less mature than the MOX Fuel estimate. The ADR estimate also lacks costs associated with program-level risks that are likely to be encountered during development and operations. Therefore, the ADR program cost estimate reported in the 2014 PWG report may be low relative to realized actual costs should the program proceed. It is very likely that the ADR program would be subject to funding constraints on capital and construction.

Option 3 Immobilization

Both reports acknowledge the need to re-open discussions under the PMDA for use of the Immobilization option. Each notes uncertainty with can-in-canister and/or glass-in-canister technology, production processes, processing facilities, and production rate, and form for disposal in a geologic repository. Each notes that a geological repository has not been identified.

The Aerospace report notes that the Immobilization option cost estimate lacks costs associated with program-level risks that are likely to be encountered during development and operations. The immobilization cost estimate includes a range estimate to account for large cost uncertainty, however, the point estimate in the 2014 PWG report is reported at the lower end of the range. Therefore, the Immobilization Program cost estimate reported in the 2014 PWG report is low relative to what may

Predecisional - Official Use Only

be realized should the program proceed. It is likely that the Immobilization program would be subject to funding constraints on capital and construction.

One significant programmatic complexity for the Immobilization is the need to co-locate the plutonium with sufficient quantities of HLW to accomplish the immobilization mission. Neither of the two candidate locations discussed in the 2014 PWG report, SRS and Hanford WA, have both ingredients in sufficient quantities to accomplish the disposition mission by themselves. These constraints, combined with current policy and agreements between the DOE and the affected states, result in dependencies that render the Immobilization Option programmatically impractical.

Option 4 Downblend

Both reports acknowledge the need to re-open discussions under the PMDA for use of the Downblend option. Both assessments indicate that the Downblend option is lower in complexity and technical and programmatic risk compared to the other options, assuming the use of an existing geologically stable repository for disposition of the downblended material. Under this assumption, no new facilities or technology development are required for this option. Each report notes the need for engagement with Federal, State and local tribal representatives in the state of New Mexico, should WIPP be proposed as the disposal site. Each report notes that changes to the WIPP Land Withdrawal Act may be required, although further study is needed to fully specify the composition of the downblended material and the packaging configuration for this to be adequately understood.

The Aerospace report notes effects related to the suspension of operations at WIPP, the repository reference model used in this study.

Aerospace assesses the basis of estimate of the Downblend program cost-to-go to be adequate for concept level costing and consistent with industry best practices. Program level cost-risk associated with dependencies between the program elements is lower than that for MOX Fuel, ADR, and Immobilization, however, the Downblend program cost estimate in the 2014 PWG report may be low relative to actual costs, should the program proceed (see the companion report, "Plutonium Disposition Study Options Independent Assessment Phase 1 Report, Option 1: MOX Fuel, Option 4: Downblend," April 13, 2015, TOR-2015-01848). The Downblend option cost is unlikely to be subject to impacts of annual funding constraints on capital improvements for processing plutonium.

Option 5: Borehole

Both reports acknowledge the need to re-open discussions under the PMDA for use of the Borehole option. Both assessments identify significant unknowns in site selection research and development, the lack of a well-posed concept and operational design, and challenges in establishing requirements for borehole disposal of plutonium.

The Aerospace report acknowledges the cost and schedule are unknown, and raises issues of site characterization, the need for permanent facilities and infrastructure, technology for drilling and emplacement, health and safety monitoring of the emplaced material, and retrievability requirements levied by current regulations that could prove difficult to meet.

Predecisional - Official Use Only

Relative Rankings

The relative ranking between the disposition options can be summarized as follows:

- The ADR project is more technically challenging and higher in cost-risk than MOX Fuel, the current Program of Record.
- Immobilization is similar in complexity to MOX Fuel, but carries high cost-risk (although difficult to quantify relative to MOX & ADR).
- Downblend is the least complex in design and operations and has the lowest cost-risk.
- A cost estimate and an end-to-end design were not provided for the Borehole option, but the concept is complex due to site selection and characterization, borehole drilling, emplacement of containers, and verification of container state-of-health.

3. Assessment Methodology

3.1 Data Sources

As a foundation for Aerospace's review, NNSA's Office of Material Management and Minimization (NA-23) organized a series of briefings for the Aerospace team detailing the five options and providing supporting technical and programmatic data for each. The majority of the information provided for this assessment addressed Option 1 MOX Fuel (the program of record), Option 4 Downblend, and feedstock production for Options 1 and 4. Information provided for Options 2, 3, and 5 was necessarily less mature and detailed than that provided for Options 1 and 4.

On January 13-14, 2015, Mr. Matt Crozat, Senior Policy Advisor, Office of Nuclear Energy, presented materials on the Advanced Disposition Reactor (ADR), and Dr. John Herczeg, Deputy Assistant Secretary for Fuel Cycle Technologies, Office of Nuclear Energy discussed ongoing R&D efforts for the deep borehole disposal option.

On January 27-29, 2015, NA-23 organized a series of briefings and tours at Savannah River Site. Ms. Jean Ridley, Director of Waste Disposition Programs Division, Savannah River Operations Office, led the team on a tour of the Defense Waste Processing Facility (DWPF). Mr. William Bates of Nuclear Materials Management Programs, SRNL, presented material on the ADR option.

On April 15, 2015, Aerospace held a telecom with Ms. Sachiko McAlhany, Senior Technical Advisor, Office of Material Management and Minimization, and Ms. Victoria Premaza, Office of Material Management and Minimization, to address additional questions in areas of program interfaces and cost profiles provided in the 2014 PWG report for Options 2, 3, and 5.

Appendix A lists the documentation provided to Aerospace in support of this assessment.

3.2 Assessment Areas

Aerospace performed an assessment of the existing cost basis of estimate and various technical and programmatic factors impacting cost and schedule for each option. Aerospace considered a number of assessment areas in order to identify factors that discriminate between the options and elicit other relevant information not captured in the 2014 PWG report. Among the assessment criteria surveyed were the landmark 1994 National Academy of Sciences (NAS) plutonium disposition study, the more recent 2012 Blue Ribbon Commission (BRC) report on America's Nuclear Future, and Aerospace Corporation internal materials on assessing risk-impact drivers.

The NAS study addresses a number of specific areas for consideration, including security risks (attractiveness of the plutonium form into and out of the process, inventory/throughput rates, residence/duration, dilution, Gamma dose, covert diversion, forcible or covert theft); economic / cost comparisons; environment, safety, health; and other factors, namely public acceptance, institutional acceptability (licensing), and other policies and objectives.

The BRC study evaluates the conventional LWR fuel cycle with more advanced energy systems, with comparisons based on safety (reactor and fuel cycle), cost (capital and operating), sustainability (fuel utilization, climate change impact, energy security due to reduced dependence on petroleum), non-proliferation and counter-terrorism, and waste management (including toxicity and longevity of

Predecisional - Official Use Only

waste, volume of waste, and repository space requirements). Not all of these factors apply to the non-reactor options being considered for this phase of the study but they are still instructive.

Aerospace Corporation internal materials for assessing risk-impact drivers are used across a variety of domain application areas. These are based on the Maxwell Risk-Driver Assessment Framework¹, and cover categories of required advancement, technical status, complexity, interaction/dependency, process controls, precision, reliability, producibility, criticality, costs, and schedule.

Based on consideration of these and other sources, the Aerospace team selected the following five assessment areas for the Phase 2 study.

1. **Project Complexity** – This assessment area addresses issues associated with the level of complexity and coordination required for activities necessary to complete facilities construction and modifications, and operate the option to complete the disposition mission. Considerations include the number of activities or functional areas defined in the workflow, program organizational and integration complexity, the number and extent to which new facilities or facility modifications are required, and the design/construction complexity required to execute the option.
2. **Program Dependencies** – This assessment area addresses issues associated with program level dependencies, such as the extent to which resources outside the control of the project are required to complete the mission. This includes resources and materials needed as inputs to the project (such as feedstock production, or storage and disposition facilities), and the extent of facility dependencies required to complete operations.
3. **Technology Drivers** – This assessment area addresses key technologies required by each option and associated areas of technology development.
4. **Basis of Estimate** – This assessment area addresses the degree to which the costs presented in the 2014 PWG report are representative of actual costs for each of the options and a comparative discussion of the pedigree of the cost-estimating basis of estimate.
5. **Other Factors** – This assessment area includes other factors such as compliance with existing or potential future environmental regulations, international commitments, oversight and governance agencies external to DOE, and regulatory and state and local issues.

¹ Abramson, Robert L. and Book, Stephen A., “A Quantification Structure for Assessing Risk Impact Drivers based on the Risk-Driver Scales of F.D. Maxwell”, 24th Annual DoD Cost Symposium, Leesburg, VA, September 1990.

4. Option 1: MOX Fuel Program

The MOX Fuel program workflow (Figure 1) starts with plutonium pits being transferred from the Pantex facility to Los Alamos National Laboratory (LANL) for disassembly. At that point, the conversion of the material to a mixed oxide is divided into three separate product lines:

- Plutonium is packaged in dissolvable containers at LANL and shipped to Savannah River Site (SRS) for dissolution in the H-Canyon facility. The plutonium is then extracted from the solution as an oxide in the HB-Line facility. Non-pit plutonium stored in K-area is also processed through the H-Canyon dissolution and HB-Line oxidation processes.
- Plutonium metal is converted to an oxide at the LANL PF-4 facility using muffle furnaces or specialized direct metal oxide (DMO) furnaces and then shipped to SRS for entry into the MOX fuel fabrication process.
- Plutonium metal is prepared and shipped to SRS for oxidation in specialized DMO furnaces to be installed in the MOX Fuel Fabrication Facility (MFFF) once complete.

The three product lines converge in the MFFF, where the plutonium products then undergo aqueous processing, are combined with depleted uranium oxide, and are fabricated into fuel pellets and ultimately fuel assembly rods for use in commercial nuclear reactors. Waste products from the MFFF processing are transferred to the Waste Solidification Building (WSB) for conversion to a form suitable for disposal. The MOX Fuel option fulfills its mission when the fabricated fuel rods are irradiated in commercial reactors such that the residual plutonium is difficult to recover.

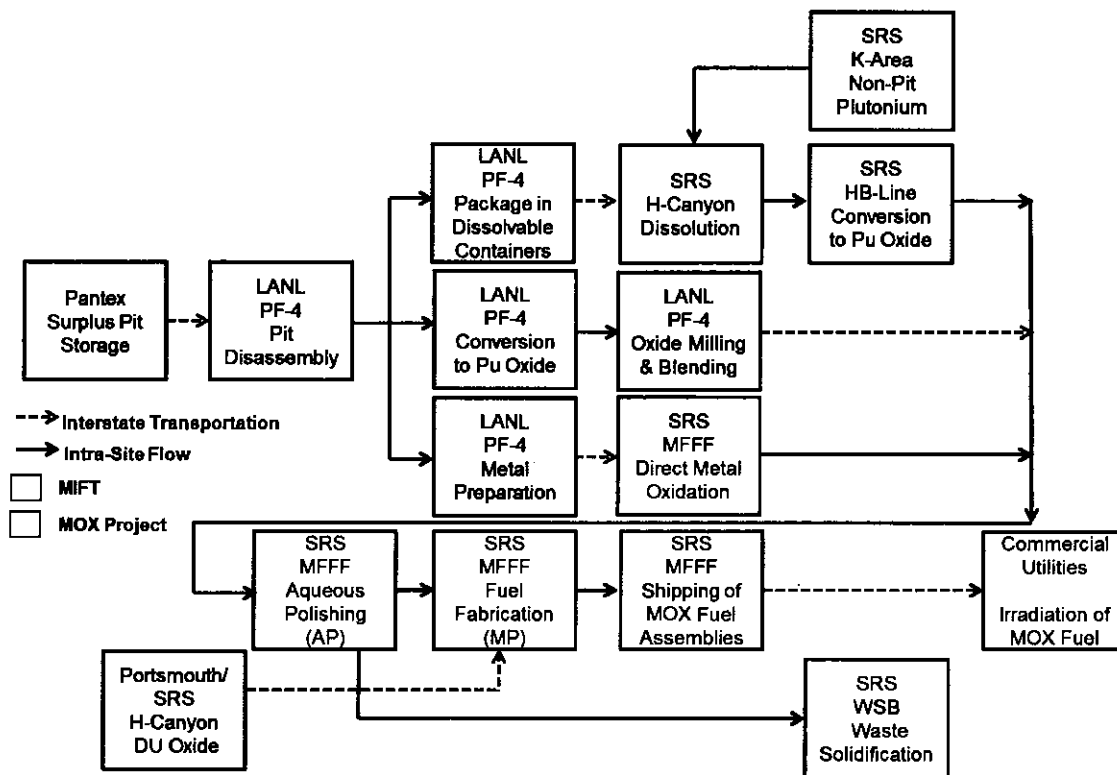

MFFF is under construction and WSB is substantially completed and in a lay-up state. Existing facilities at LANL and SRS require some degree of modification to support the mission.

Figure 1. MOX Fuel Program Workflow

4.1 Project Complexity

The MFFF is the first-of-its-kind facility in the U.S. and the first major nuclear construction project authorized by the NRC in over 20 years. The project is technically challenging and complex in its execution. The MOX facilities are unique, requiring very complex engineering and a robust design that is not susceptible to a single-point failure. The building structures are designed and constructed to stringent engineering standards in order to withstand seismic and wind events, properly handle and process the plutonium, and address nuclear criticality safety requirements. The facility incorporates innovative design features in key building subsystems, such as an extensive system of gravity-flow piping for the transport throughout the building of solvents and solutions used in the aqueous processing of plutonium. This design solution was chosen in order to minimize the use of pumps and valves, which can be prone to failure. However, it requires large quantities and lengths of piping to be engineered and installed to precise slopes and angles to ensure that the aqueous materials flow at the required rates during operation. This system requires fabrication and installation to within tight tolerances, with interfaces to the facility structure and other support systems that may be specified to less stringent tolerances. Other key subsystems, such as glove-boxes, support equipment and automated processing hardware are highly integrated, and interfaces to the facility will require allowances to be planned and built into these systems.

MFFF development requires a workforce of highly skilled engineers and tradesmen with experience in construction methods for nuclear facilities, specialized equipment and construction techniques, and well-established material suppliers. As indicated in a 2014 GAO report², the contractor on the MOX project has had difficulty identifying suppliers and subcontractors able to fabricate and install equipment in accordance with nuclear quality assurance criteria³. Consequently, it is anticipated that the design complexity and the challenges related to the supply chain for this option will add cost and schedule risk through completion of construction.

4.2 Program Dependencies

Participation from the Commercial Utilities. Currently, there is uncertainty as to whether commercial utilities will accept and use MOX fuel. Duke Energy participated in some early testing of MOX fuel assemblies at its Catawba nuclear plant but opted out of the final of three scheduled tests⁴. The absence of commitments by utilities to participate in this program may be attributed to uncertainty in the time frame in which MOX fuel is expected to be available. The degree to which utilities accept and utilize MOX fuel directly affects the time frame for completion of the plutonium disposition mission, which in turn could increase the life cycle costs for the MOX fuel program if production rates need to be adjusted to account for a lower level of utility participation.

There is also the potential for schedule impacts related to licensing requirements and facility modifications required to adapt commercial reactors to use a plutonium-based fuel. The facility

² GAO report to the Subcommittee on Energy and Water Development, and Related Agencies, Committee on Appropriations, House of Representatives; "Plutonium Disposition Program; DOE Needs to Analyze the Root Causes of Cost Increases and Develop Better Cost Estimates". GAO-14-231, February 2014 (U. S. Government Accountability Office)

³ U.S. Government Accountability Office, "Plutonium Disposition Program; Report to the Subcommittee on Energy and Water Development, and Related Agencies, Committee on Appropriations, House of Representatives," February 2014.

⁴ "Duke Energy Won't Do More MOX Tests," Augusta Chronicle, November 17, 2009. Accessed Feb 2015 at http://chronicle.augusta.com/stories/2009/11/17/met_556022.shtml

downtime required to make these modifications could adversely affect a plant's operations and delivery capability for standing contracts. Additional cost may be incurred to maintain security measures in the presence of plutonium fuel at the commercial facilities.

Other Facilities and Programs. Facilities at Pantex, LANL, SRS, and Portsmouth provide the materials and services related to the production of feedstock. If the start of MOX fuel production is delayed, then additional resources may be required to recapitalize aging or obsolete equipment, maintain or return to readiness for operations, and complete necessary preparations for startup.

The spent MOX fuel rods are currently assumed to be stored on site at the commercial reactor facility; however, there are security implications associated with the long-term storage of the spent fuel rod material that may require further study.

4.3 Technology Drivers

Commercial Reactor Modifications and Specific Fuel Qualification. The MOX concept is based on an existing MOX facility in France with a demonstrated operation and production track record. In the United States, implementation includes changes due to variances in the regulatory regime. In addition there is the need to accommodate differing fuel requirements associated with varying commercial light-water reactors types. Since the US commercial reactor designs and configurations differ, the specific fuel types may vary with each plant. There are also uncertainties associated with the MOX fuel qualification and physical reactor plant modifications required. This may require additional technology investment to prototype fuel assemblies and demonstrate operation prior to reactor facility certification by the NRC.

Use of Automation for MOX Fuel Fabrication. Extensive use of operational automation, control systems, and associated operational software is planned for MFFF. The use of automation in the MFFF glove boxes and other processing steps adds a layer of safety for operators but also introduces technology and programmatic risk to the system development and validation process. Additional accommodations for maintenance of the automated and software-intensive systems must also be accounted for across the program life cycle. Uncertainty in the complexity and extent of automated production support systems translates into uncertainty in the level and qualification of staffing needed to operate and maintain these advanced systems.

4.4 Basis of Estimate

The cost estimate for the MOX Fuel option in the 2014 PWG report is based on post CD-3 data available in the 2012 time frame, for construction, operations, and feedstock production. Individual program elements have a cost basis of estimate developed in a manner consistent with industry best practices, and are adequate for concept level costing. However, program level cost-risk associated with dependencies between the program elements was underestimated, and as a result the MOX Fuel program cost estimate reported in the 2014 PWG report is judged to be low relative to what may be realized at completion of construction and operations. However, sufficient detail was available in the 2014 PWG estimate for use as a point of departure in assessing changes since the 2012 time frame, and for performing a sensitivity analysis to assess program risk. (A full description can be found in the "Plutonium Disposition Study Options Independent Assessment Phase 1 Report, Option 1: MOX Fuel, Option 4: Downblend," April 13, 2015, TOR-2015-01848.)

The costs provided for MFFF construction are based on a bottom-up contractor estimate for a mature design currently in execution (post CD-3), with reference to experience with the French facility currently in operation. The MFFF construction estimate has undergone separate independent review

Predecisional - Official Use Only

and was revised as recently as 2012, based on that review as well as actual design and construction experience up to that point in time. The estimate includes contingency based on uncertainty analysis provided by the contractor.

Uncertainty in MFFF construction cost arises from several sources. The design-build acquisition approach results in uncertainty in the remaining design and construction work scope to complete the project. Uncertainty exists in the number, unit cost, and availability of specialized materials and hardware elements. The level of complexity in construction activities associated with the remaining 40-60% of the work is higher than for the work accomplished to date. Finish work on the remaining plumbing systems and equipment installations may require additional time and labor resources and could involve a greater likelihood of need for re-work. Uncertainty exists in the work scope for the integration of automated functions, control systems, and software. Workforce attrition may occur for both general and specialized construction skills due to competition in the labor market.

The WSB at Savannah River has been constructed to substantial completion and placed in layup status. "Substantial completion" denotes the facility has met regulatory requirements for occupancy, but it is noted that some items are incomplete. WSB costs-to-go are based on contractor estimates for annual layup and restart costs, and assumptions on both the lay-up period and the subsequent years of operation. This is a single point estimate and does not include contingency based on uncertainty analysis. One of the primary uncertainties is the number of years WSB will remain in lay-up and the implications for cost growth with an aging, unused facility and the need for increased recapitalization costs over time.

The estimate of MFFF Operations costs are based on a contractor proposal for the initial years of operation, with the annual cost extrapolated through the full projected duration of operations. However, the assumed operational timeframe is in turn based on assumptions regarding the completion of construction, facility availability, and rates of production and delivery of feedstock and fuel rods.

The MOX Fuel Irradiation, Feedstock, and Transportation Program (MIFT) cost estimates address the conversion of plutonium pits into feedstock, qualification of the fuel for use in commercial reactors, and fuel transportation and storage. The estimated costs for feedstock production are based on recent operational experience at SRS H-Canyon and the Aries feedstock pilot program at LANL PF-4, although it should be noted that this latter point of reference is a factor of three to four times smaller in scale and timeline than that required for full feedstock production. Both the LANL and SRS estimates were revised in 2013-2014, but planning for production facilities in PF-4 and validation of production operations are not complete.

Program Integration costs address site integration, management, and landlord services for MFFF and WSB at Savannah River. The estimates provided are based on a known site location and recent operational experience. This is a single point estimate and thus does not include contingency based on uncertainty analysis.

Finally, note that execution of the MOX Fuel option is vulnerable to annual funding constraints on capital expenditure, due to the large cost of major construction projects.

4.5 Other Factors

Conforms to U.S. Approach and Criteria in the PMDA. Irradiation of MOX fuel in Light Water Reactors (LWRs) corresponds to the U.S. disposition method specified in the PMDA. This is the

Predecisional - Official Use Only

only option that would not require a supplementary agreement to the Plutonium Management Disposition Agreement (PMDA) with Russia.

NRC Licensing. The NRC will impose re-licensing requirements for those commercial power plants participating in the MOX program. As noted in the 2014 PWG report,⁵ NRC regulations and licensing experience are primarily geared for construction and operations of commercial nuclear reactors using uranium rather than plutonium-based fuels. Consequently, there is some risk that the regulations may drive construction activities during the licensing processes, potentially with schedule and cost implications. The GAO report⁶ identifies NRC regulations as one of the causes contributing to cost growth of the MOX option.

A related aspect of this issue is that the NRC and DOE have unique policies and regulations related to nuclear energy processes and requirements, particularly with safety but also related to licensing. This may introduce cost and/or schedule impacts if policy or regulatory differences need to be reconciled. Moreover, DOE policies and NRC regulations are subject to change, which may impact cost and schedule for programs with long construction timelines.

IAEA Monitoring. The MOX Fuel project has held several meetings with the branches of the IAEA to review the MFFF design with respect to incorporating a PMDA verification regime in the available physical space. This ensures that the appropriate verification equipment could be readily accommodated at a later date once the facility is completed. There do not appear to be significant challenges in meeting the IAEA monitoring requirements at this time. However, given the uncertainty in the time to complete MFFF construction, including the fact that portions of the detailed design will not be completed until subcontractors and vendors are contracted to perform the work, there is the potential for further work being needed to support the IAEA monitoring regime.

Areva Financial Status. Areva SA, one of the joint owners of MOX Services⁷, is a French multinational group specializing in nuclear and renewable energy. The French Atomic Energy Commission holds 54% ownership with the French government itself holding 29%.⁸ On March 6, 2015, Standard & Poor's downgraded Areva's credit rating to BB- following a 2014 loss of €4.8 billion (\$5.29 billion). Areva SA has incurred multi-billion euro cost overruns on two fixed-price reactors under construction, including a €5.4 billion overrun on a €3.2 billion contract.⁹ Areva SA is currently studying options to raise capital, including a merger with EDF (a French utility company, also largely owned by the French government), sale of uranium mines, and sale of its nuclear transport (TNI) and nuclear decommissioning (STMI) units.¹⁰ The impact of this financial situation on the MOX Fuel project will depend on whether Areva is able to secure additional funding for ongoing operations, either through public or private sources, but the net effect of either a significant restructuring or a bankruptcy may be disruptive to MFFF construction.

⁵ Report of the Plutonium Disposition Working Group: Analysis of Surplus Weapon Grade Plutonium Disposition Options, U.S. Department of Energy, April 2014.

⁶ GAO-14-231, "Plutonium Disposition Program: DOE Needs to Analyze the Root Cause of Cost Increase and Develop Better Cost Estimates," February 2014

⁷ According to CB&I's most recent 10-K report, the MOX project is a joint venture with CB&I owning 52% and Areva owning 48%. Chicago Bridge & Iron Company N.V., Form 10-K, 31 Dec. 2014. SEC website. Accessed 16 Mar. 2015.

⁸ "Capital Structure," Areva. Accessed 14 Mar. 2015

⁹ "S&P downgrades Areva debt further into junk status," Reuters, 6 Mar. 2015. Accessed 14 Mar. 2015.

¹⁰ Ibid.

Predecisional - Official Use Only

State and Local Issues. Nuclear activist groups are active in South Carolina. Legal filings by environmental and/or anti-nuclear activist groups and resulting delays may increase as the facilities and processes comprising the MOX option approach completion, licensing and operation.

5. Option 2: Advanced Disposition Reactor

The Advanced Disposition Reactor (ADR) option utilizes plutonium metal fuel for irradiation in a fast-spectrum burner reactor. The ADR program workflow (Figure 2) starts with transfer of plutonium pits from the Pantex facility to Los Alamos National Laboratory (LANL) and Savannah River Site (SRS) for disassembly and size reduction. The modified plutonium metal is transferred to K-Area Material Storage (KAMS), where it is prepared for fuel fabrication.

Fuel is fabricated in a new K-Area Fuel Fabrication Facility (KAFF), to be constructed in part of the K-Reactor building within the K-Area Complex at SRS. Fuel is consumed by the ADR to produce electricity. Spent fuel is stored at a new NRC-licensed Independent Spent Fuel Storage Installation (ISFSI) at SRS.

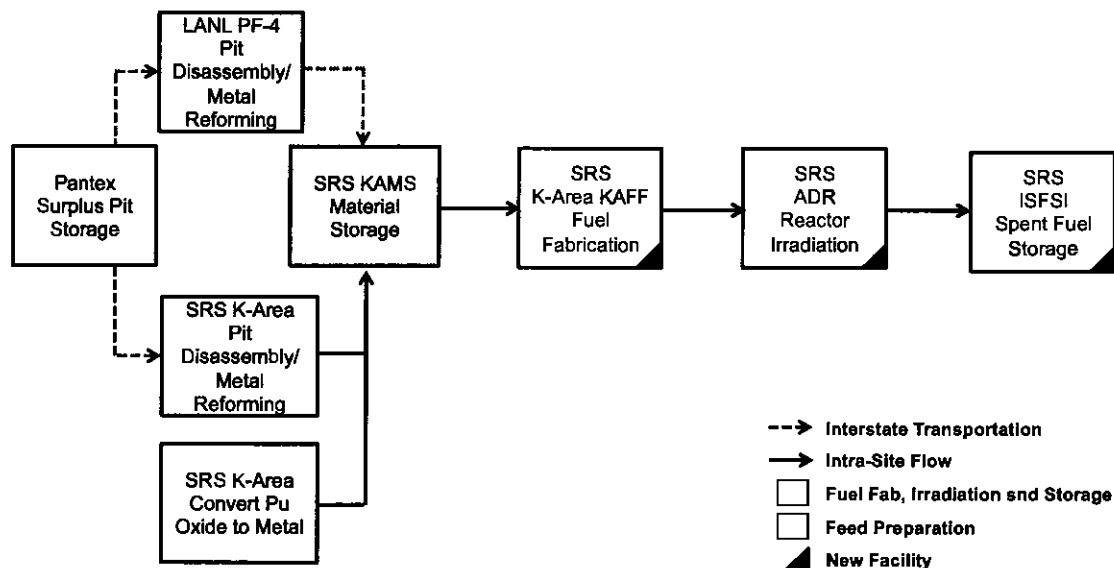

1. Spent fuel assumed to be stored on site at an "Independent Spent Fuel Storage Installation" (ISFSI).
2. KAFF, ADR, and ISFSI are new facilities; all other facilities require some level of modification to accomplish the mission.

Figure 2. ADR Program Workflow

5.1 Project Complexity

The ADR project is more technically challenging and complex than the MOX Fuel option. New facilities are needed for plutonium metal processing, fuel fabrication, and spent fuel storage. Execution of design and construction in an NRC licensing environment is new for advanced liquid metal reactors and will require hundreds of nuclear qualified suppliers and construction workers over a decade or more. Conversely, ADR fuel production may involve fewer specialized facilities than MOX Fuel because the fuel is more tolerant of impurities.

5.2 Program Dependencies

Solid Fuel Fabrication Facility Siting. Development of a new solid fuel fabrication process within K-Area at SRS has not been fully defined. Historically, solid fuel for liquid metal reactors in the U.S. has been built at the Fuel Manufacturing Facility (FMF) at Idaho National Lab (INL). Siting the facility at SRS may require the transfer of the knowledge base, workforce, and technology from INL to SRS.

Participation from Commercial Utilities. Although data was not provided specifically addressing how the electricity produced by the ADR would be used, it is assumed that it would be sold to the commercial utilities and integrated into the power grid. This would require an interface with the ADR and associated modifications on the part of the utilities to enable this integration. Like the MOX Fuel option, this may require acceptance and commitment by the commercial utilities.

Industrial Base Issues. The ADR project will demand a specially trained workforce of highly skilled engineers and tradesmen, specialized equipment, and well-established material suppliers. As indicated for MOX, identifying suppliers and subcontractors who are able to fabricate and install equipment meeting nuclear quality assurance criteria will likely continue to be difficult. Consequently, it is anticipated that the design complexity and the challenges related to the supply chain will add potential risk to the ADR project.

The U.S. has never built an NRC-qualified Liquid Metal Fast Reactor, and hasn't built a fast reactor since the late 1970s at Hanford (the Fast Flux Test Facility, FFTF) to test fuel and cladding materials for the Clinch River Breeder Reactor which was canceled in 1983. The lack of recent experience in building a liquid metal fast reactor, coupled with the lack of NRC experience with licensing of advanced (non-LWR) reactors, will result in unknown technical challenges in the design, development, construction, and licensing of the ADR.

Liquid metal fast nuclear reactor design knowledge has declined and the nuclear construction industry has diminished over the past decades. As a result, acquiring an experienced workforce to assist in the design, construction, and regulation may pose significant challenges. From industry's perspective, the Nuclear Energy Institute (NEI) reported in 2010: "Nearly 38 percent of the nuclear industry work force will be eligible to retire within the next five years. To maintain the current work force, the industry will need to hire approximately 25,000 more workers by 2015."¹¹ The nuclear industry and the NRC will be seeking expertise from the same finite pool of candidates.

Enrollment in nuclear science and engineering undergraduate and graduate programs has also declined, forcing nuclear engineering programs at universities to merge with other disciplines or to shut down completely (UCLA's nuclear engineering program is a prime example, having gone from a standalone to a merged to a non-existent program). According to the American Nuclear Society, 65 nuclear engineering university programs existed in the country in 1980; fewer than 30, less than half, survived in 2007¹². In 2012, a Blue Ribbon Commission stated, "We recommend expanded federal, joint labor-management, and university-based support for advanced science, technology, engineering,

¹¹ Nuclear Energy Institute Fact Sheet, Work Force: Nuclear Industry's Comprehensive Approach Develops Skilled Work Force for the Future, September 2010.

¹² Nuclear's Human Element: Defining the Federal Government's Role in Sustaining a Vibrant U.S. University-Based Nuclear Science and Engineering Education System for the 21st Century, American Nuclear Society, February 2007.

and mathematics training to develop the skilled workforce needed to support an effective waste management program as well as a viable domestic nuclear industry.”¹³

5.3 Technology Drivers

Dated Fast Reactor Design. The liquid metal cooled reactor for the ADR option is based on a conceptual design for General Electric Hitachi’s Power Reactor Innovative Small Module (PRISM), which is over 20 years old and consequently may require significant redesign and associated research and development investment.

A pre-application safety evaluation conducted by the NRC of the PRISM design in 1994 stated:

“Despite many years of successful operation with metal fuel in the Experimental Breeder Reactor-II (EBR-II), the differences in material, geometry, and operating conditions are such that direct application of that experience to the PRISM design is difficult without additional fuel and material testing, safety tests, and analytical model development ... [the prior operational] experience must be extrapolated to the PRISM design through the use of analytical tools that characterize the operational history and transient responses of the fuel system. Experimental data must be obtained both to support the model development efforts and to verify the integrated computer codes.”¹⁴

The NRC subsequently terminated its PRISM review efforts after DOE cancelled ALMR work in 1994. Given the age of the PRISM design and likely changes in technologies and processes in the intervening years, there is a high degree of technical risk in the implementation of the baseline ADR design.

Solid Fuel Qualification. Fuel assembly qualification for the proposed advanced reactor has not been completed, which will impact cost and schedule. According to a more recent NRC report, “An acceptable fuel qualification test program would need to demonstrate high levels of safety performance and reliability of the reactor fuel as a barrier to fission product release during normal operation and for the selected accident conditions.”¹⁵

Sodium Reactor Core Coolant. Based on experience with existing fast reactors that utilize sodium as the reactor core coolant, fires and steam explosions have been major problems during operations. A number of plants have been shut down for long periods of time in the past as a result of sodium fires.¹⁶ A research report of the International Panel on Fissile Materials on fast reactor programs highlights the maintenance and repair challenges at fast reactors:

“The reliability of light-water reactors has increased to the point where, on average, they operate at 80 percent of their generating capacity. By contrast, a large fraction of sodium-cooled demonstration reactors have been shut down most of the time that they should have been generating electric power. A significant part of the problem has been the difficulty of maintaining and repairing the reactor hardware that is immersed in sodium. The requirement to keep air from coming into contact with sodium makes refueling and repairs inside the reactor

¹³ Blue Ribbon Commission on America’s Nuclear Future, Report to the Secretary of Energy, January 2012.

¹⁴ “Preapplication Safety Evaluation Report for the Power Reactor Innovative Small Module (PRISM) Liquid-Metal Reactor,” U.S. Nuclear Regulatory Commission, February 1994

¹⁵ Report to Congress: Advanced Reactor Licensing, U.S. Nuclear Regulatory Commission, August 2012

¹⁶ “Fast Breeder Reactor Programs: History and Status,” A Research Report of the International Panel on Fissile Materials, February 2010

Predecisional - Official Use Only

vessel more complicated and lengthy than for water-cooled reactors. During repairs, the fuel has to be removed, the sodium drained and the entire system flushed carefully to remove residual sodium without causing an explosion. Such preparations can take months or years.”¹⁷

The net impact of such extensive maintenance processes (or outright shutdowns in operations due to accident) would be to increase the time period necessary to complete the disposition mission, with attendant increases in cost.

5.4 Basis of Estimate

The ADR Program estimate in the 2014 PWG report is based on concept level cost estimates developed in the 1990s. The quality and completeness of the estimate is difficult to assess due to both the age of the source data provided and the maturity of the concept in comparison to the MOX Fuel option. The estimate does not include costs for the Independent Spent Fuel Storage Installation (ISFSI) for storing the spent plutonium fuel rods. Program level cost-risk associated with dependencies between the program elements is underestimated. Therefore the ADR Program cost estimate reported in the 2014 PWG report may be low relative to realized actual costs should the program proceed. Due to the uncertainty in the pedigree and level of detail of the cost information provided, Aerospace was unable to validate the costs presented in the 2014 PWG report, or perform a sensitivity analysis to assess program cost-risk. Development of a more rigorous concept-level estimate for the ADR program could be achieved after further concept development work which would include updates to the 1990 cost estimates.

The construction costs provided for the ADR and the KAFF are based on analogies to early concept design of green-field facilities that were produced in the 1990's. The analogies used were the Power Reactor Innovative Small Module (PRISM) concept, and the Pit Plutonium Disassembly and Conversion Facility (PDCF) concept, respectively. However, neither of these facilities were actually constructed so the analogy cost estimate is not based on actual costs of similar facilities. Engineering judgment and scaling were then used to adjust the estimates from a green-field development model to one of adapting existing facilities, and for effects of code revisions and changes to regulatory environments since the 1990s, NRC licensing of a first-of-a-kind reactor, and other uncertainties. This estimate is a single point cost and does not include contingency based on uncertainty analysis.

Cost estimates for operations are based on current K-Area operational costs and engineering judgment for incremental staffing, security, and indirect costs extrapolated through the projected duration of operations.

Feedstock production cost is based on the MIFT estimate created for Option 1, MOX Fuel, and is not adjusted to account for savings from elimination of the plutonium metal oxidation step in the feedstock production.

Program Integration costs address site integration, management, and landlord services at SRS and are based on an assumed site location (K-Area complex at SRS) and recent operational experience. This estimate is a single point cost and does not include contingency based on uncertainty analysis.

Execution of the ADR option is highly likely to be vulnerable to annual funding constraints on capital due to the large cost of the construction projects.

¹⁷ Ibid

5.5 Other Factors

Modification of PMDA. The ADR approach would require discussions with Russia regarding use of this option under the disposition agreement, pursuant to existing PMDA provisions. Such an agreement is permitted under Article III (1) of the PMDA. As a result of the 2010 Protocol amendment to the PMDA, Russia changed its approach to irradiate plutonium in fast reactors rather than LWRs, and thus it is not unreasonable to presume that Russia would be amenable should the U.S. opt for the same disposition strategy, however, this presumption involves a degree of risk.

NRC Licensing. NRC regulations and licensing experience are primarily geared for design, construction and operations of commercial nuclear reactors using uranium versus plutonium-based fuels. In a report to Congress on the licensing of advanced reactors, NRC states

“For non-LWR advanced reactor technologies, however, the research base is much more limited and, for some beyond-the-horizon design concepts, almost nonexistent. For this reason, the NRC expects that significant research efforts will need to be undertaken to support the agency’s licensing decisions. Such research must be conducted so that the analysis methods and experimental data can support an independent safety finding by the NRC staff.”¹⁸

Moreover, DOE policies and NRC regulations are subject to change, which creates the potential for additional impact to project cost and schedule, especially given the decades-long timelines for construction and operations of the KAFF, ADR, and ISFSI. Consequently, an estimate of the time required for NRC licensing of the ADR would necessarily contain significant uncertainty.

IAEA Monitoring. The IAEA monitoring requirements for ADR are unknown, but would be expected to follow the same development path as for the MOX Fuel option. Negotiations would be needed with the branches of the IAEA to review the ADR design with respect to incorporating a PMDA verification regime, so that the verification equipment can be accommodated within the facility. Given the uncertainty in the time to complete detailed ADR design and construction, there is the potential for significant further work being needed to support the IAEA monitoring regime.

State and Local Issues. Nuclear activist groups are active in South Carolina. Legal filings by environmental/anti-nuclear activists and consequential delays to a project start date may increase as fuel fabrication, ADR, and spent fuel facility development activities progress toward filings of environmental impact reports.

¹⁸ Report to Congress: Advanced Reactor Licensing, U.S. Nuclear Regulatory Commission, August 2012.

6. Option 3: Immobilization Program

The Immobilization program workflow (Figure 3) starts with the transfer of plutonium pits from Pantex to LANL, where they are disassembled and divided into two product lines:

- Packaging plutonium in dissolvable containers at LANL for dissolution at SRS H-Canyon and conversion to an oxide with the existing supply of non-pit plutonium stored in K-area.
- Conversion of plutonium to mixed oxide at LANL using muffle furnaces and/or specialized direct metal oxide (DMO) furnaces.

The two product lines converge at SRS, where the plutonium oxide is milled to reduce the size of the powder and achieve a uniform distribution. The powder is then blended with either a borosilicate glass frit or a titanate-based ceramic that immobilizes the plutonium. This material is then placed in stainless steel cans and transferred to a HLW vitrification facility (presently not defined) where the cans are loaded into larger canisters and filled with High Level Waste (HLW) that has been melted into glass to produce a waste form suitable for repository disposal. To complete the process, the material is then packaged and transported to a geologically stable underground repository (presently not defined) for disposition.

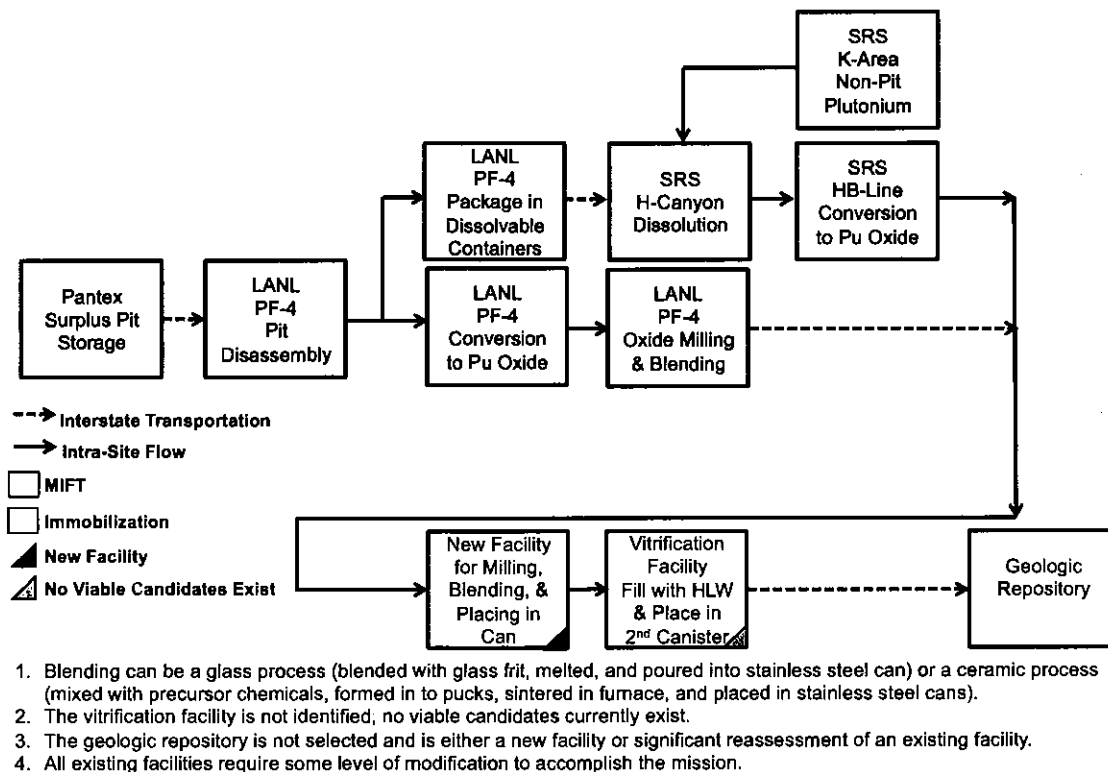

Figure 3. Immobilization Program Workflow

6.1 Project Complexity

The processes used in the Immobilization approach are of similar complexity to MOX Fuel. Immobilization requires fewer steps, but relies on more mechanical processes, compared to the more

innately chemical processes used for MOX. Feedstock preparation for Immobilization is similar in complexity to that of the Downblend option, discussed in Section 7. However, the disposal processes involved are more complex than for the Downblend overall due to the specific nature of the immobilization processing steps and the use of HLW. Additional safety processes will be needed to mitigate risk of potential exposure to personnel and equipment, which will add complexity to the design and implementation.

New facilities are proposed for milling, blending, and conversion of plutonium to a glass or ceramic form, and vitrification of HLW. These new facilities are at the conceptual level and will require further development.

One significant programmatic complexity for the Immobilization Option is the need to co-locate the plutonium with sufficient quantities of HLW. Neither of the two candidate locations discussed in the 2014 PWG report, SRS and Hanford WA, have both ingredients in sufficient quantities to accomplish the disposition mission by themselves. These constraints, combined with current policy and agreements between the DOE and the affected states, result in dependencies that render the Immobilization Option programmatically impractical.

6.2 Program Dependencies

Insufficient HLW. There is insufficient HLW remaining at SRS for disposition of the 34 MT of plutonium. Although Hanford has a large amount of liquid HLW in storage, it is intended for remediation through the Waste Treatment and Immobilization Plant (WTP) currently under construction at Hanford. Even if the HLW at Hanford were available, the challenges involved in transferring the material to SRS for use in immobilization of plutonium would be difficult to execute both politically and economically. Transporting large quantities of HLW would require the development and acquisition of a new transportation carrier system certified to carry liquid HLW, as well as staging and transfer facilities at both Hanford and SRS. Transportation of HLW from Washington to South Carolina would require negotiation and regulatory approval from each affected state and the federal government.

Use of Existing or Planned Vitrification Facilities. The location of facilities for vitrification of HLW and immobilization of the plutonium within the HLW is undefined, and the likelihood of utilizing existing or planned vitrification facilities for these purposes is low. Both the Defense Waste Processing Facility (DWPF) at SRS and the WTP at Hanford will require modifications to support the immobilization option. Modifications to the DWPF and operational testing will interrupt and impact its current mission to disposition the remaining HLW at SRS. The DWPF is currently scheduled for closure in 2032, and immobilization of plutonium is estimated to continue to at least 2060¹⁹. Assuming that the DWPF operational life is extended beyond 2032, it would be a 60-plus year-old facility. Ongoing maintenance and recapitalization of an aging plant, or development of a new facility, will add cost and schedule to the project.

The WTP will also require modifications that are outside the scope of current agreements between the State of Washington and the DOE for this facility. Such modifications would be disruptive to WTP development and operations. Moreover, use of the WTP as part of the immobilization option would require the transportation of plutonium to the state of Washington and is therefore not considered further.

¹⁹ Report of the Plutonium Disposition Working Group: Analysis of Surplus Weapon-Grade Plutonium Disposition Options, U.S. Department of Energy, April 2014.

Predecisional - Official Use Only

Geologic Repository. A geologic repository for permanent disposition of the immobilized material is not identified, and will require considerable study to determine a viable site location. Geology and related environmental investigations will influence design and engineering decisions that, depending on what is discovered, could directly impact cost and schedule. The Waste Isolation Pilot Project (WIPP) is currently the only geologic repository in the United States, and cannot accept HLW under provisions of the Land Withdrawal Act. Amending the Act to accommodate this purpose would require congressional approval.

Temporary Storage Facilities. If a permanent geologic repository is not available or not ready to accept the immobilized waste, additional temporary storage facilities will be required. SRS has encountered this issue in the execution of the DWPF's current mission. In 2012 the DWPF had temporary storage for about 4,600 canisters of vitrified liquid waste and planned to expand that storage to account for the then expected 7,800 canisters total²⁰; however, as of May 2014, the canister count has increased by 10% to 8,582 total canisters, necessitating additional storage at a third, yet to be completed Glass Waste Storage Building²¹.

6.3 Technology Drivers

Immobilization technology maturity. Immobilization of plutonium oxide in ceramic or glass form with high-level waste is not a new concept, but specific processes have yet to be defined. There is uncertainty in the long-term properties of the can-in-canister configuration and material behavior of plutonium in ceramic form. Both the ceramic and glass form options require further evaluation, research and development, laboratory testing, and product qualification prior to the development of a full scale production process.

6.4 Basis of Estimate

The Immobilization estimate in the 2014 PWG report is based on similarity to the MOX Fuel option and other assumptions. Program level cost-risk associated with dependencies between the program elements is underestimated, however, range estimates were provided for the major capital and operational cost elements to reflect the known uncertainty in the estimate. The cost provided for this option does not include construction of a repository for the immobilized material, and point estimates derived from the range estimate were reported at the lower end of the range. Therefore, the Immobilization Program cost estimate reported in the 2014 PWG report is low relative to what may be realized should the program proceed. Due to the uncertainty in the pedigree and level of detail of the cost information provided, Aerospace was unable to validate the costs presented in the 2014 PWG report, or perform a sensitivity analysis to assess program cost-risk. Overall, the Immobilization option estimate is less mature than that for the MOX Fuel option. Development of a more rigorous concept-level estimate could be achieved after further concept development work.

Capital costs for construction of a new immobilization facility, waste processing facility, and storage facilities are based on adjustments to the current estimate for the MOX Fuel option. The rationale for the use of the MOX construction costs as the basis for the immobilization construction costs is similarity, at a high level, of the technical processes utilized in the two options. Adjustments are made to the MOX Fuel option estimate to remove aqueous polishing steps from the processing flow for immobilization. Costs are added to the estimate to account for the vitrification process, which for this

²⁰ Defense Waste Processing Facility Fact Sheet, Savannah River Remediation, LLC, Feb 2014, retrieved April 22, 2015 from http://www.srs.gov/general/news/factsheets/srr_dwfp.pdf

²¹ SRR-LWP-2009-00001, Liquid Waste System Plan, Rev. 19, Savannah River Remediation, LLC, Savannah River Site, Aiken, South Carolina, May 2014.

estimate was based on the WTP at Hanford, WA with cost added for a new or reconstituted plutonium storage facility.

Preliminary designs from the past immobilization program of record were not updated for use in the estimate for the immobilization option. The amount of R&D and technology development included in the estimate is unknown. The 2014 PWG Report recognized this large uncertainty by providing a capital cost range estimate that was estimated via engineering judgment. However, the 2014 PWG Study's point estimates utilized the low estimate of the range and so there could be large additional capital cost, should the actual costs lie higher within the estimated range.

The Operations cost estimate addresses immobilization facility processing and storage operations to encapsulate and store the full 34 MT of plutonium covered under the PMDA. The costs provided are based on current MFFF operational cost estimates, adjusted to subtract the aqueous polishing process. The estimate recognizes the large uncertainty by providing an operations cost range estimate estimated via engineering judgment. Again, the 2014 PWG Study's point estimates utilized the low estimate of the range thus there could be additional operations costs should the actual costs lie higher in the given range.

Feedstock costs address converting the plutonium pits into feedstock and transporting and storing the material. The same MIFT estimate created for Option 1, MOX Fuel, was reused for this option due to the similarities to MOX fuel with respect to these factors.

Program Integration costs address site integration, management, and landlord services for a new immobilization facility. The costs provided are based on an assumed site locations and recent operational experience. However, there is much more uncertainty in the immobilization facility design than for the MFFF, and the ability to site such a facility at Hanford is in question. This is a single point estimate and thus does not include contingency based on uncertainty analysis.

Execution of the Immobilization option is likely to be vulnerable to annual funding constraints on capital due to the extensive construction projects that the option entails.

6.5 Other Factors

Modification of PMDA. As with all non-reactor options, the Immobilization option would require discussions with the Russians and written agreement regarding its acceptability under the disposition agreement, pursuant to existing PMDA provisions. Such an agreement is permitted under Article III (1) of the PMDA and therefore it is anticipated that reaching agreement would not be a lengthy process compared with a complete renegotiation. However, there are certain risks with negotiating for a non-reactor based approach. By way of background, both countries originally agreed to a mainly MOX-fuel approach: Russia would dispose of its 34 MT by irradiating MOX in LWRs, while the U.S. would use the same approach for the majority of its plutonium, but would dispose of 8.4 MT via immobilization, this secondary method having since been cancelled due to budget constraints). Subsequently, Russia changed its approach to irradiate plutonium in fast reactors rather than LWRs, but fundamentally the Russian approach is still a reactor-based one. Re-opening of discussions with Russia may be required to reach agreement on a U.S. disposition approach that is reliant on geologic emplacement. The amount of time required to reach such an agreement is an unknown and therefore poses schedule risk.

Regulatory Uncertainty for Geologic Repository. The regulatory requirements imposed by agencies such as the Environmental Protection Agency (EPA), the NRC and DOE for the selection and location of the geologic repository remain uncertain, and as a result the impacts to the facility

Predecisional - Official Use Only

construction and disposal operations cost and timeline are unknown. Changes to the safety basis or policy and regulatory requirements over time may also impact operational processes and associated staffing levels required to execute them.

State and Local Issues. There will likely be close scrutiny of candidate locations for siting the geologic repository, by numerous entities at the state, local, and possibly tribal levels. Environmental assessments and hearings may follow a lengthy course, potentially impacting the individual project and overall program schedules. Modifications to policy and existing agreements to site facilities for converting plutonium to glass or ceramic form, and HLW vitrification, and/or to enable interstate transportation of HLW or plutonium may be met with strong state and local resistance.

IAEA Monitoring. Although complexity of the independent monitoring process is anticipated to be less for Immobilization than for the MOX Fuel and ADR options, considerable uncertainty remains. It is unclear what monitoring process will be needed to account for the plutonium as it transitions through multiple facilities to final disposition at the repository.

7. Option 4: Downblend Program

The Downblend program workflow (Figure 4) starts with the transfer of plutonium pits from the Pantex facility to LANL where they are disassembled and divided into two product lines:

- Packing plutonium in dissolvable containers at LANL for dissolution at SRS H-Canyon and conversion to an oxide with the existing supply of non-pit plutonium stored in K-area.
- Conversion of plutonium to mixed oxide at LANL using muffle furnaces and/or specialized direct metal oxide (DMO) furnaces.

The two product lines converge at SRS, where the mixed oxide is combined in small amounts with a larger amount of inert material, significantly reducing the mass and volumetric fraction of plutonium in the downblended material. The downblended material is then packaged and transported to an existing geologically stable underground repository for disposition. For the purposes of this study, the Waste Isolation Pilot Project (WIPP) was used as the reference for the repository.

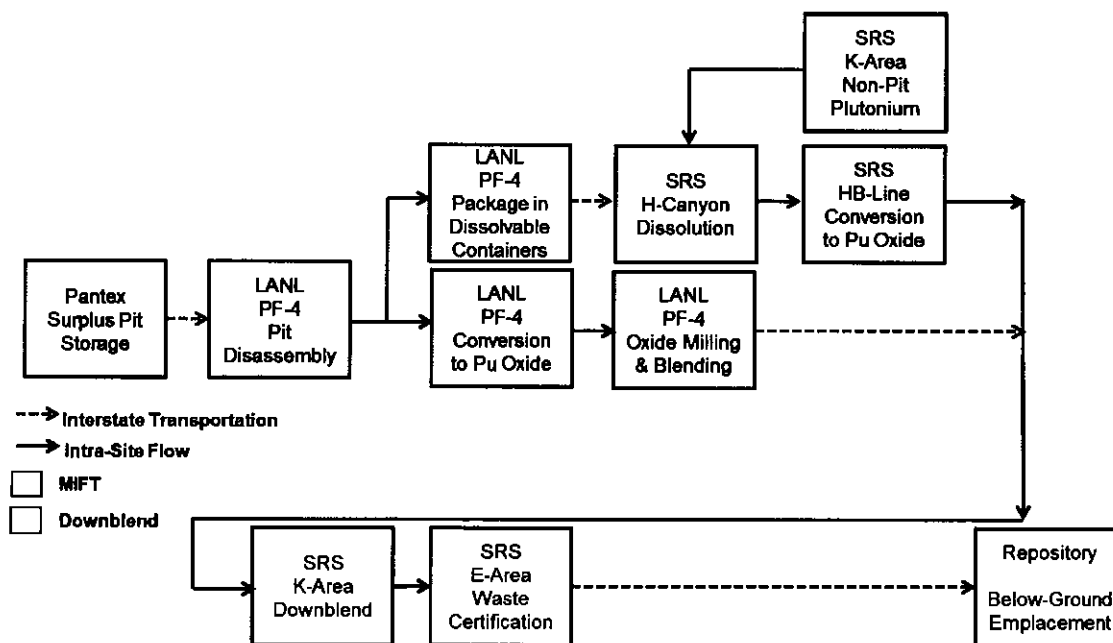

1. No new facilities are required. Existing facilities at LANL and SRS require some degree of modification to support the mission.
2. Assumes an existing repository for disposition of the downblended material.

Figure 4. Downblend Program Workflow

7.1 Project Complexity

In comparison to the other alternatives, the Downblend program is considered the least complex. From a facilities standpoint, no new facilities need to be constructed. Facility modifications involve adding two additional gloveboxes to the K-area at SRS for handling the downblended material and packing operations, and infrastructure improvements to accommodate the needed operational processes. Although this is not expected to pose a major technical challenge, there may be difficulties related to the modifications necessary to properly retrofit an older facility, as well as changes to the safety basis that could impose additional facility or process requirements. These factors could

Predecisional - Official Use Only

potentially lengthen the duration of the program. There will have to be coordination with other ongoing operations at K-area that could result in some impacts to the disposition mission schedule.

7.2 Program Dependencies

Availability of a Repository for Permanent Disposal of Downblended Material. The Downblend option is dependent on a geologically stable underground repository for permanent disposal of the transuranic (TRU) downblended material, the availability of which remains a potential issue. Two unrelated February 2014 incidents (a salt haul truck fire and the breach of a storage cask, resulting in radiological release into the environment) at WIPP, the repository reference model used in this study, resulted in the suspension of operations at the site for receipt of transuranic waste. The accident investigation was concluded in 2015, and DOE is implementing a recovery plan. Since WIPP is currently the only domestic repository capable of permanently storing the downblended material, any disruption to its long-term operations has direct impact to the viability of the Downblend option. If for any reason WIPP becomes unavailable for this purpose, another facility would need to be selected, constructed and certified for use.

7.3 Technology Drivers

The technologies required to support this option are judged to be mature, and no requirements for additional technology research or development activities are identified.

7.4 Basis of Estimate

The Downblend option cost estimate in the 2014 PWG report is based on feedstock production cost estimates for the MOX Fuel option and existing glove box acquisition and installation costs at SRS. The Downblend estimate is comparable in maturity to that for the MOX Fuel option, assuming the use of an existing repository for disposition of the downblended material. Individual program elements were found to have cost bases of estimate that were developed in a manner consistent with industry best practices and are adequate for concept level costing. Program level cost-risk associated with dependencies between the program elements is lower than that for the MOX Fuel, ADR, and Immobilization options. However, the Downblend program cost estimate in the 2014 PWG report may still be low relative to actual costs, should the program proceed, due to these inter-element dependencies. Sufficient detail was available to use as a point of departure in assessing changes since the 2012 time frame and for performing a sensitivity analysis to assess program risk. (A full description can be found the companion report, "Plutonium Disposition Study Options Independent Assessment Phase 1 Report, Option 1: MOX Fuel, Option 4: Downblend," April 13, 2015, TOR-2015-01848.). An accurate estimate of the cost of the Downblend option program requires a decision on the use of an existing repository vs. the development of a new facility for final disposition of the material, clearly a major cost driver.

Capital costs for this option include installation of two additional glove boxes in the K-Area complex at SRS and incremental costs for emplacement of the downblended material at the existing WIPP repository in New Mexico. The estimates provided are based on existing glove box installations both at K-Area and other DOE nuclear facilities. In developing the estimate, it was recognized there is moderate technology uncertainty that could involve new research and development effort, even though the technologies used are relatively mature. To accommodate this uncertainty, a capital cost range estimate was provided, based on engineering judgment. However, the 2014 PWG Study's point estimates utilized the low estimate of the range, thus there could be additional capital cost, should the actual costs lie higher in the given range.

Predecisional - Official Use Only

Operations costs address downblending operations at SRS and emplacement operations, assuming the use of WIPP. The costs provided are based on recent operational experience at the K-Area complex and WIPP. A degree of uncertainty was accommodated in this estimate via an operational cost range, which was estimated via engineering judgment. However, as with the capital cost estimate, the 2014 PWG Study's point estimate for operations costs reflected the low end of this range, thus there could be additional operations cost should the actual costs lie higher in the given range.

The feedstock production process for the Downblend option is nearly identical to that for the MOX Fuel option, allowing the detailed MIFT estimate created for MOX fuel to be used.

Program Integration costs address site integration, management, and landlord services for the K-Area complex at SRS. The costs provided are based on an assumed location within the existing K-Area complex and recent operational experience. This estimate is a single point cost and thus does not include contingency based on uncertainty analysis.

The Downblend option requires little or no technology development and is based on a relatively simple design as compared with the MOX Fuel, ADR, and Immobilization options. Assuming the use of an existing geologic repository, execution of this option is not likely to be vulnerable to annual funding constraints on capital, due to its relatively low capital investment needs.

7.5 Other Factors

Modification of PMDA. The Downblend option will require re-opening discussion with the Russians and modification of the PMDA. Although it is anticipated that modification of the agreement would not be a lengthy process compared with a complete renegotiation, there are certain risks with non-reactor based approaches. Time required to reach an agreement is a variable and therefore poses schedule risk.

Security Basis Change Due to Quantity of Material to be Dispositioned. The 2014 PWG report stated that based on current environmental permitting requirements an amendment to the Land Withdrawal Act for WIPP would be necessary based on calculations for total space required for emplacement of 34 MT of downblended plutonium,²² however this remains an open question. If an amendment is needed, Congressional approval would be required, along with potential involvement of the EPA.

A number of methods for increasing the amount of material that can be disposed within the current constraints of the Land Withdrawal Act are being investigated by the Department of Energy. The current baseline plan is to package 380 fissile-gram equivalent (FGE) of downblended plutonium into criticality control overpack (CCO) packages to be shipped to the repository. An alternative approach to increase the loading per can from 380 FGE in CCOs up to 1000 FGE using 9975 containers is being considered. Because of uncertainties in whether there is sufficient volume available at the repository, the higher loading afforded by this alternative is attractive from a space perspective; however, the higher loading would likely change the shipments from a Category III (less than 500 g per IAEA guidelines²³) to II rating, resulting in associated costs for storage and transport to meet higher security requirements.

²² Report of the Plutonium Disposition Working Group: Analysis of Surplus Weapon Grade Plutonium Disposition Options, U.S. Department of Energy, Apr. 2014.

²³ IAEA Information Circular (INFCIRC) 225 Revision 5, Nuclear Security Recommendations on Physical Protection of Nuclear Material and Nuclear Facilities, Jan 2011.

Predecisional - Official Use Only

Regulatory Changes. With the February 2014 incident of radiological release through the exhaust system into the environment, and subsequent suspension of waste receipt operations at WIPP, there are uncertainties related to regulatory requirements that might be imposed on a new or existing geologic repository. Cost and schedule impacts are implicit but unknown at this time, adding risk to the program.

IAEA Monitoring. Although complexity of independent monitoring is anticipated to be less than for the MOX Fuel and ADR options, it is unclear what monitoring process will be needed to account for the plutonium as it transitions through multiple facilities to disposition at the repository.

State and Local Issues. Local tribal groups and nuclear activist groups are active in New Mexico. If WIPP is selected as the repository for the Downblend option, the potential for legal filings by these activists and consequential delays may increase. The same risk holds true for any potential revisions/amendments to the Land Withdrawal Act that might be driven by the volume calculation assumptions as outlined in the Plutonium Disposition Working Group, as discussed above.

8. Option 5: Borehole

The Borehole option involves disposal of surplus plutonium in deep geologic boreholes in suitable canisters. Boreholes are drilled into crystalline basement rock approximately 5,000 meters deep, with canisters emplaced in the lower 2,000 meters of the borehole. The Borehole program workflow is not defined in the 2014 PWG Report, but may involve plutonium metal and/or oxide and will require further research and development to resolve uncertainties and allow for a more comprehensive evaluation. Figure 5 depicts the Borehole program workflow.

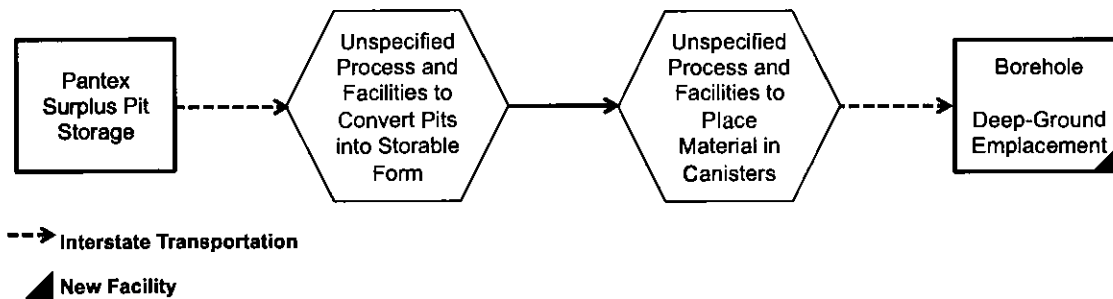

Figure 5. Borehole Program Workflow

8.1 Project Complexity

Although relatively simple in concept, emplacement of plutonium in deep boreholes requires assessment of several elements of the disposal system that have yet to be demonstrated, the major elements being drilling of a borehole of sufficient diameter and depth,²⁴ loading the storage containers into the borehole to the appropriate depth, and verifying their integrity and state of health once emplaced.

Site Support Facilities. Site support facilities will be needed from initiation of borehole construction activities through waste emplacement operations. These facilities may include a receiving and processing area, security and perimeter fencing, administrative facilities, cafeteria, storage, electrical power generation, water supply, waste disposal, and other utilities. New facilities, likely at SRS, will also be needed for canister processing. Depending on how remote the borehole is, a fire station and an emergency health clinic may also be required.

Site Characterization. Characterizations of the geochemical environment and borehole region geology will need to be performed to include the crystalline basement rock structural properties such as density and porosity, volcanic intrusions, seismic risk, faults and fractured zones, gravity and magnetic properties, electrical resistivity of rock formations groundwater structures, and temperature parameters. It is also critical to understand the potential impacts and risks to the canisters and their emplacement within these geologic conditions, such as canister material properties and potentially corrosive mineral effects.

²⁴ Sandia National Laboratories. Research, Development, and Demonstration Roadmap for Deep Borehole Disposal, August 2012

Post-Emplacement State of Health and Safety. Operations to emplace the material, verify the integrity of the containers, and perform long term state of health monitoring of the emplaced material may require very high reliability, long life *in situ* monitoring capabilities on each container, and a means of communicating information from the depths of the borehole to the surface.

8.2 Program Dependencies

Borehole Site(s) Not Identified. The borehole option will require considerable study efforts to determine site location, including geological and environmental assessments in order to define design-engineering/construction solutions. Site location accounts for a significant percentage of costs related to project construction costs. Geology and related environmental investigations, depending on what is discovered, will influence design/engineering solutions that directly impact cost and schedule.

8.3 Technology Drivers

Borehole Site Concept is Unproven. The borehole concept for emplacement of plutonium is unprecedented and dependent on unproven technology. There is no specific evidence that placing materials at significant depths would keep them safely isolated from the environment for as long as or longer than the current geologic repository technique, and further study would be required to validate the concept. Technical basis and characterization of the deep borehole design, thermal effects on hydrologic environment, and the chemical environment would require further study. Extensive R&D and engineering analyses would need to be performed to build confidence in the viability of the concept and also the eventual ability to obtain operational licensing/certifications.

There are several research and development topics needed to support this option:

Drilling technology and feasibility: Advances in technology have helped in decreasing the cost of drilling large diameter boreholes with several kilometers of depth; this contributes to the potential feasibility of the deep borehole disposal concept. Drilling deep boreholes greater than 2km in depth have been accomplished, including a 6 km deep petroleum exploration borehole in Nevada²⁵ and the 12,262 m Kola super-deep scientific borehole in Russia.²⁶ However, the completion of a borehole with the required diameter and depth for emplacement has not been demonstrated. Although drilling deep boreholes using proven technology borrowed from the petroleum industry appears feasible, drilling crystalline rock for the purpose of emplacing plutonium-derived material requires further research and development of associated technologies and techniques.

Casing & sealing (borehole plugs) technology and effectivity: The emplacement of casing within the borehole and borehole seals pose significant technological challenges. The casing provides borehole stabilization, protecting the borehole walls from collapse during drilling and also against the pressures exerted against the wall from fluids and gases that might be encountered over the operational life of the borehole. The potential for inadequate sealing between the casing and surrounding rock is a major concern for the deep borehole concept, since an insufficient seal might be difficult to detect by well logging and could provide a hydrologic pathway to the surface.²⁷

²⁵ Sapeii, B., & Driscoll, M. J. (2009). A Review of Geology-Related Aspects of Deep Borehole Disposal of Nuclear Waste.

²⁶ Sandia National Laboratories. Research, Development, and Demonstration Roadmap for Deep Borehole Disposal, August 2012

²⁷ Beswick, J. (2008). Status of Technology for Deep Borehole Disposal: EPS International Report for Contract No. NP 01185 . U.K. Nuclear Decommissioning Authority (NDA)

Predecisional - Official Use Only

The path of least resistance for environmental forces acting on the borehole wall will be vertically upward through the sealed borehole and adjacent disturbed host rock, where permeability is likely to be higher than that of the undisturbed bedrock.²⁸ Materials capable of effective, long-term sealing of the borehole above the emplaced material would have to be developed and subsequently demonstrated. Several related R&D projects have been proposed over the years and are also in work, such as backfilling with materials like concrete and bentonite or taking advantage of the heat produced by the waste to encapsulate waste packages in melted rock.²⁹ It should be noted that none of these approaches have been subjected to *in situ* testing. Additional performance testing of engineered materials, seal designs and applications would be required, incurring additional schedule and costs for the program.

Characterizing geologic composition as barrier (over long term): The typical precept of nuclear waste disposal is the practice of using multiple barriers (engineered and natural) that work together to ensure the long-term containment of waste and radiation. The deep borehole disposal strategy currently being developed for containment/emplacement of plutonium depends primarily on the geology selection and the depth of material emplacement. Long-term effects of radiation within geologic boreholes needs further study. Although radioactive waste emplaced in crystalline rock boreholes would be more effectively isolated than waste emplaced in geologic repositories,³⁰ minimum separation distances will also need to be established and maintained to preclude potential interactions.

Emplacement of waste in boreholes: Currently, no concept or engineering exists to support the functional operation of waste emplacement in a deep borehole. It is anticipated that specialty equipment will need to be developed and fabricated to support the emplacement. However, the technical challenges for emplacement in deep boreholes are anticipated to be similar to those associated with emplacement in geologic repositories so the expectation is that viable solutions will be derived. Given that hundreds of waste canisters will be emplaced to dispose of the 34 MT of plutonium, a very high reliability system will need to be developed to emplace the canisters without jamming or stalling so to avoid permanently blocking the borehole.

Process for Ready Material for Storage is Undefined. Given the lack of concept precedence, a new research activity will be required to both convert the plutonium pits into a storable form and to design and qualify a canister destined for emplacement in a deep borehole. Geological chemistry and thermal impacts of plutonium disposal when emplaced in the borehole will need to be studied to understand the implications to canister material and design. Limitations of drilling diameters versus canister diameters will also need to be established.

8.4 Basis of Estimate

A cost estimate was not provided for the Borehole option (Option 5 in the 2014 PWG Report), and a concept design description was not available for review. Development of a more detailed concept design, demonstration of the key technologies, and selection of candidate sites need to be accomplished before program cost for this option can be adequately estimated.

²⁸ Sandia National Laboratories. (2009). Sandia Report: Deep Borehole Disposal of High-Level Radioactive Waste. Sandia National Laboratories.

²⁹ Nirex. (2004). Nirex Report no. N/108; A Review of the Deep Borehole Disposal Concept for Radioactive Waste.

³⁰ Sandia National Laboratories. (2009). Sandia Report: Deep Borehole Disposal of High-Level Radioactive Waste. Sandia National Laboratories.

8.5 Other Factors

Modification of PMDA. The Borehole option will require re-opening discussion with the Russians and modification of the PMDA. Although it is anticipated that modification of the agreement would not be a lengthy process compared with a complete renegotiation, there are certain risks with non-reactor based approaches. Time required to reach an agreement is a variable and therefore poses schedule risk.

Changes to Regulations. The Nuclear Waste Policy Act (NWPA) would require amendment since it currently only applies to the geologic repository at Yucca Mountain in Nevada, rather than deep boreholes. Additionally, Yucca Mountain was subject to site-specific EPA and NRC regulations (40 CFR Part 197 and 10 CFR Part 63), both of which would presumably need to be similarly developed for any identified borehole site(s). An alternative would be to pursue development of non-site-specific regulatory standards for deep borehole disposal (similar to NRC's 10 CFR Part 60) but either approach would be expected to take many years (Yucca Mountain regulatory approval for DWPF glassified waste took between 5 and 10 years.³¹) Additionally, if use of deep boreholes is pursued as a plutonium waste disposition option, it is likely that the U.S. would also want to use this approach to dispose of other HLW and spent nuclear fuel, since Yucca Mountain is no longer viewed as a viable option. This would further complicate the regulatory development and approval process.

Retrievability. The Blue Ribbon Commission on America's Nuclear Future discusses the concepts of retrievability (the ability to retrieve emplaced nuclear waste material from a geologic repository, for example, if the emplaced materials are not behaving as expected) and reversibility (the ability to reconsider and reverse course during any phase of a geologic disposal program).³² Current regulations (40 CFR 191 and 10 CFR 60.111(b)) place requirements on the retrievability of waste:

“Disposal systems shall be selected so that removal of most of the wastes is not precluded for a reasonable period of time after disposal.” (40 CFR 191.14 (f))

“To satisfy this objective, the geologic repository operations area shall be designed so that any or all of the emplaced waste could be retrieved on a reasonable schedule starting at any time up to 50 years after the waste emplacement operations are initiated, unless a different time period is approved or specified by the NRC.” (CFR 60.111(b))

Due to the depths involved with deep boreholes (3 – 5 km), the retrievability requirements levied by current regulations could prove to be difficult to meet (and at a minimum would impose additional technical complexities to accomplish), or require modification (e.g., demonstration of what a “reasonable period of time” means for the borehole concept).

State and Local Issues. There will be scrutiny at the state and local levels regarding candidate locations and anticipated opposition by special interest groups. Environmental assessments and hearings, providing a public platform for the public to raise concerns, are anticipated to be a lengthy process potentially impacting the overall project and program schedules. With the environmental and siting activities, it is also possible that legal issues may be raised, requiring negotiation or becoming potential roadblocks to the project and/or impacts to schedule.

³¹ Telecon with Sachiko Mcalhany, Senior Technical Advisor, Office of Material Management and Minimization, NNSA, April 2015.

³² Blue Ribbon Commission on America's Nuclear Future, Report to the Secretary of Energy, January 2012.

9. Common Program Dependencies Impacting Cost and Schedule

All of the plutonium disposition options have common dependencies among program elements that have the potential to impact cost and schedule. These dependencies are driven by a number of factors, such as assumptions on production of feedstock, competition from other programs for physical space and infrastructure of shared facilities, changes to the safety basis and regulatory requirements, and workforce availability. Uncertainty in the funding of out-year operations may impact the ability to adequately staff and maintain steady state production goals. Production operations may be temporarily suspended, as the safety oversight process continually evaluates the effectiveness of process and safety controls across the spectrum of operational activities in all facilities. Higher overhead costs at the facilities associated with a given option will result in increases to overall program costs. Similarly, uncertainty in the out-year costs to maintain shared services and infrastructure may result in increased costs to all disposal programs.

10. Key Observations

The following summarizes the key points for Project Complexity for each alternative:

Option 1 – MOX Fuel

- MOX Fuel utilizes a first-of-its-kind facility in the U.S., and it is the first major nuclear project authorized by the NRC in 20 years.
- The program is technically and programmatically complex in its execution and operation.
- The MOX Fuel program has had difficulty in identifying suppliers and subcontractors able to fabricate and install equipment meeting nuclear quality assurance criteria.

Option 2 – ADR

- The ADR project is more technically challenging and complex than MOX Fuel.
- ADR requires development for new fuel production, irradiation, and disposition facilities.

Option 3 - Immobilization

- Immobilization is similar in complexity to MOX Fuel.
- Immobilization requires new facilities for blending, milling and immobilization, and disposition.

Option 4 - Downblend

- Downblend is the least complex in design and operations compared with MOX Fuel, ADR, and Immobilization.
- Downblend does not require the development of new facilities, assuming the availability of an existing repository for disposal of the downblended material.

Option 5 - Borehole

- The Borehole option, though simple in concept, has considerable complexities related to site selection and characterization, resolution of design uncertainties, borehole drilling, emplacement of containers, and verification of container state-of-health once emplaced.
- The option requires development of new facilities at the borehole site to support construction, emplacement, and long term monitoring operations.
- Plutonium processing and packaging for emplacement in the borehole is undefined.

The following summarizes the key points for Program Dependencies for each alternative:

Option 1 – MOX Fuel

- Uncertainty regarding the level of participation from commercial utilities to accept and use MOX fuel.
- External facilities may require additional resources to maintain their readiness should delays in start of operations continue to occur.
- The method for long-term storage of spent plutonium-based fuel rods is undefined.

Option 2 – ADR

Predecisional - Official Use Only

- ADR development will be subject to industrial base issues in the areas of workforce and knowledge base due to contraction of the nuclear industry and reduced offerings of undergraduate and graduate programs in nuclear science and engineering.
- Expertise in solid fuel fabrication technology at INL may need to be leveraged for a new fuel fabrication facility at SRS.
- Interface for ADR to the commercial power grid.

Option 3 – Immobilization

- There is insufficient HLW remaining at SRS for disposition of the 34 MT of plutonium.
- The location of facilities for vitrification of HLW and immobilization of the plutonium within the HLW is undefined, and the likelihood of utilizing existing facilities is low.
- A geologic repository for disposition of the immobilized waste is not identified.
- If a permanent geologic repository is not readily available, expanded temporary storage facilities will be required.

Option 4 – Downblend

- A permanent disposal repository for the downblended material has not been definitively identified.

Option 5 – Borehole

- A borehole site has not been identified.

The following summarizes the key points for Technology Drivers for each alternative:

Option 1 – MOX Fuel

- Commercial reactor modifications and specific fuel qualification may require additional technology investment.
- Extensive use of automation in the MFFF adds complexity and there is uncertainty in the operation and maintenance of these systems.

Option 2 – ADR

- The dated fast reactor design carries significant risk and requires significant developmental work.
- Solid fuel qualification will likely impact cost and schedule.
- Safety of operations and maintenance of the reactor core with the use of sodium metal as a coolant is a technology driver.

Option 3 – Immobilization

- Technology and processes for both the glass and ceramic-based immobilization approaches need to be developed and demonstrated.

Option 4 – Downblend

- None.

Option 5 - Borehole

- The borehole site concept is unproven and will need research in drilling technology, sealing methods, geologic characterization, and methods of waste emplacement and retrieval.

Predecisional - Official Use Only

- Research will be required to select appropriate methods to convert the plutonium pits into a storable form and to design/qualify a canister for emplacement in a deep borehole.

The following summarizes the key points for Basis of Estimate for each alternative:

Option 1 – MOX Fuel

- Individual program elements have a cost basis of estimate that is adequate for concept level costing and were done in a manner consistent with industry best practices.
- Program level cost-risk is underestimated, therefore the cost estimate reported in the 2014 PWG report is low relative to what may be realized at completion of construction and operations.
- Execution of the MOX Fuel option is vulnerable to annual funding constraints on capital due to the large cost of the associated construction projects.

Option 2 – ADR

- ADR is higher in cost-risk than MOX Fuel, Immobilization, and the Downblend options due to its lower design maturity.
- The ADR estimate is based on concept level cost estimates developed in the 1990s, and the quality and completeness is difficult to assess due to the age of the estimate.
- Program level cost-risk is underestimated, therefore the cost estimate reported in the 2014 PWG report is low relative to what may be realized at completion of construction and operations.
- Execution of the ADR option is highly likely to be vulnerable to annual funding constraints on capital due to the large cost of the associated construction projects.

Option 3 – Immobilization

- The Immobilization option carries high cost risk, although it is difficult to quantify relative to MOX Fuel and ADR.
- The Immobilization estimate in the 2014 PWG report is based on similarity to the MOX Fuel option and other assumptions.
- Program level cost-risk is underestimated, therefore the cost estimate reported in the 2014 PWG report is low relative to what may be realized at completion of construction and operations.
- Execution of the Immobilization option is likely to be vulnerable to annual funding constraints on capital due to the construction projects that would be entailed.

Option 4 – Downblend

- Program level cost-risk associated with dependencies between the program elements is lower than that for MOX Fuel, ADR, and Immobilization.
- The Downblend estimate is comparable in maturity to the MOX Fuel option, assuming the use of an existing repository for disposition of the downblended material.
- Program level cost-risk is underestimated, therefore the cost estimate reported in the 2014 PWG report is low relative to what may be realized at completion of construction and operations.
- Execution of the Downblend option is not likely to be vulnerable to annual funding constraints on capital, since significant capital construction is not required.

Option 5 – Borehole

Predecisional - Official Use Only

- A cost estimate was not provided for the Borehole option in the 2014 PWG Report.

The following summarizes the key points for Other Factors for each alternative:

Option 1 – MOX Fuel

- The MOX Fuel option conforms to U.S. approach in the PMDA.
- Risks exist with respect to re-licensing commercial nuclear plants to accept and process MOX fuel.
- Availability of necessary skill and experience within the NRC to oversee startup of this plutonium-based facility is a risk.
- There do not appear to be significant challenges in meeting the IAEA monitoring requirements at this time.
- Areva's financial difficulties may impact MFFF construction.
- Legal filings at the state and local levels by environmental/anti-nuclear activists could cause delays to start of operations.

Option 2 – ADR

- This option would require negotiations with Russia regarding use of this option under the PMDA.
- The process time for NRC licensing of a fast reactor is presents an unknown degree of schedule risk.
- There is the potential for significant further work needed to support the IAEA monitoring requirements.
- Legal filings at the state and local levels by environmental/anti-nuclear activists could cause delays to start of operations.

Option 3 – Immobilization

- This option would require negotiations with Russia regarding use of this option under the PMDA.
- Since the selection and location of the geologic repository are undetermined, there is uncertainty in the regulatory requirements that could be levied by agencies such as the EPA, NRC, and DOE.
- IAEA monitoring and verification will be required, but the implementation approach is uncertain.
- Legal filings at the state and local levels by environmental/anti-nuclear activists could cause delays to start of operations.

Option 4 – Downblend

- This option would require negotiations with Russia regarding use of this option under the PMDA.
- A security basis change may be required due to quantity of material to be dispositioned.
- IAEA monitoring and verification will be required, but implementation is uncertain.
- There are uncertainties related to the regulatory requirements that might be imposed on a new or existing geologic repository.
- Legal filings at the state and local levels by environmental/anti-nuclear activists could cause delays to start of operations.

Option 5 – Borehole

Predecisional - Official Use Only

- This option would require negotiations with Russia regarding use of this option under the PMDA.
- The Nuclear Waste Policy Act (NWPA) would require amendment.
- The retrievability requirements levied by current regulations could prove to be difficult to meet.
- Legal filings by local or state interest groups could cause difficulties in site selection and production goals.

Table 1 Key Point Summary

	Option 1 –MOX Fuel	Option 2 –ADR	Option 3 - Immobilization	Option 4 - Downblend	Option 5 - Borehole
Project Complexity	<ul style="list-style-type: none"> • First-of-its-kind facility in U.S. and first nuclear project authorized by NRC in 20 years • Technically and programmatically complex • Difficulty in identifying suppliers and subcontractors able to meet quality assurance criteria 	<ul style="list-style-type: none"> • More technically challenging and complex than MOX • Requires development of significant new fuel production, irradiation, and disposition facilities 	<ul style="list-style-type: none"> • Similar in complexity to MOX • Requires development of new milling & blending, immobilization, and disposition facilities 	<ul style="list-style-type: none"> • Least complex in comparison with MOX, ADR, and immobilization • No new facilities are required, assuming use of existing repository 	<ul style="list-style-type: none"> • Complexity drivers include site selection and characterization, design, borehole drilling, emplacement of containers, and verification of container state-of-health once emplaced • Requires development of new facilities to support borehole construction, emplacement, and long-term monitoring operations • Plutonium processing and packaging for emplacement is undefined.
Program Dependencies	<ul style="list-style-type: none"> • Uncertain participation of commercial utilities to use MOX Fuel • External facilities may require additional resources to maintain readiness • Long term storage of spent plutonium fuel rods is undefined 	<ul style="list-style-type: none"> • Development subject to industrial base issues in workforce and knowledge base • Expertise in INL solid fuel fabrication may be need to be leveraged at SRS • Interface for ADR into commercial power grid 	<ul style="list-style-type: none"> • There is insufficient HLW remaining at SRS for disposition of 34 MT of plutonium • The location of facilities for vitrification of HLW and immobilization of the plutonium within the HLW is undefined, and the likelihood of utilizing existing facilities is low • Geologic repository not identified • Expanded temporary storage facilities may be required 	<ul style="list-style-type: none"> • Availability of a repository for permanent disposal of downblended material 	<ul style="list-style-type: none"> • Borehole site not identified
Technology Drivers	<ul style="list-style-type: none"> • Commercial reactor modifications and specific fuel qualification • MFFF automation technology 	<ul style="list-style-type: none"> • Dated fast reactor design • Solid fuel qualification • Operational safety issues due to sodium reactor core coolant 	<ul style="list-style-type: none"> • Ceramic and glass-based immobilization approaches need further development 	<ul style="list-style-type: none"> • None 	<ul style="list-style-type: none"> • Borehole site concept unproven • Method to convert the plutonium pits into a storable form and canister design undefined
Basis of Estimate	<ul style="list-style-type: none"> • Cost basis of estimate is adequate for concept level costing • Program level cost-risk is underestimated, therefore the cost estimate is low relative to what may be realized at completion of construction and operations • Vulnerable to funding constraints on capital due to the large cost of construction projects 	<ul style="list-style-type: none"> • ADR is higher in cost-risk than the MOX Fuel, Immobilization, and Downblend options • Quality and completeness is difficult to assess • Program level cost-risk is underestimated, therefore the cost estimate is low relative to what may be realized at completion of construction and operations • Highly likely to be vulnerable to funding constraints on capital due to the large cost of construction projects 	<ul style="list-style-type: none"> • Immobilization option carries high cost risk although difficult to quantify relative to MOX Fuel and ADR • Estimated based on similarity to the MOX Fuel option & other assumptions • Program level cost-risk is underestimated, therefore the cost estimate is low relative to what may be realized at completion of construction and operations • Likely to be vulnerable to funding constraints on capital due to the construction projects that would be entailed 	<ul style="list-style-type: none"> • Program level cost-risk associated with dependencies between the program elements is lower than that for MOX Fuel, ADR, and Immobilization • Estimate is comparable in maturity to MOX Fuel, assuming the use of an existing repository for disposition • Program level cost-risk is underestimated, therefore the cost estimate is low relative to what may be realized at completion of construction and operations • Not likely to be vulnerable to funding constraints on capital 	<ul style="list-style-type: none"> • No cost estimate is provided.
Other Factors	<ul style="list-style-type: none"> • Conforms to U.S. approach in the PMDA • Utility licensing risks for MOX fuel • NRC oversight issues • No significant IAEA issues • Areva financial status an issue • Environmental activist issues 	<ul style="list-style-type: none"> • Requires negotiations with Russia • NRC licensing issues • IAEA monitoring requirements • Environmental activist issues 	<ul style="list-style-type: none"> • Requires negotiations with Russia • Regulatory uncertainty for geologic repository • IAEA verification regime undefined • Environmental activist issues 	<ul style="list-style-type: none"> • Requires negotiations with Russia • Security basis change may be required • IAEA verification regime undefined • Uncertain regulatory requirements on existing or new geologic repository • Environmental activist issues 	<ul style="list-style-type: none"> • Requires negotiations with Russia • NWPA amendment required • Retrievability requirements difficult • Environmental activist issues

11. Assessment of 2014 PWG Report

Key observations from Aerospace's assessment are generally consistent with the 2014 PWG Report's discussion in areas of *Technical Viability*, *International Commitments*, and *Other Factors* but differ in the areas of *Cost-to-go* and *Completion Timelines*. Comparison of the key observations between the 2014 PWG Report and this assessment are summarized for each option below.

Option 1 MOX Fuel

Both the Aerospace independent assessment and the 2014 PWG report acknowledge that the MOX Fuel option meets current PMDA requirements. Both assessments acknowledge that the MOX Fuel project is technically and programmatically complex with significant risk associated with the completion of construction and facility startup. Both reports note uncertainties associated with the NRC licensing process, facility certification, fuel qualification, and participation by the commercial nuclear power industry in completing the disposition mission, each of which introduces risk into the program. Both assessments note the challenges in maintaining workforce and suppliers with the requisite experience in nuclear facilities, systems, and operations.

The Aerospace report cites additional programmatic risk associated with overall program integration of key program element interfaces and dependencies between feedstock production, MOX Fuel production, participation by the commercial nuclear power industry, and uncertainties in operations and production rates.

Aerospace assesses the basis of estimate of the MOX Fuel program cost-to-go to be adequate for concept level costing and consistent with industry best practices. However the 2014 PWG report cost estimate is low relative to what may be realized at completion of construction and operations, due primarily to the absence of consideration for programmatic risk associated with the program element interdependencies and the impacts of annual funding constraints on MFFF construction (see the companion report, "Plutonium Disposition Study Options Independent Assessment Phase 1 Report, Option 1: MOX Fuel, Option 4: Downblend," April 13, 2015, TOR-2015-01848).

Option 2 ADR

Both reports acknowledge that changes will be required to the PMDA to accommodate the ADR option. Both reports acknowledge the high technical and programmatic risks inherent in the necessary research and development, technology demonstration, full-scale design, construction, and startup of an advanced fast spectrum burner sodium cooled reactor. Both reports acknowledge that additional new facilities for metal fabrication will be required, incurring additional technical and programmatic risk. It is expected in both reports that the NRC licensing process and fuel qualification process will be lengthy.

ADR is the most complex and technically challenging option. The Aerospace assessment notes significant issues with the industrial base, including the adequacy of the workforce, fast reactor knowledge base, and the need for a significant R&D and technology development and demonstration phase prior to reaching CD-2. Long term storage of spent plutonium metal fuel rods may require a different approach than that used for spent commercial uranium fuel rods, and may require the development of a new facility. As with the MOX Fuel option, the Aerospace assessment cites additional programmatic risk associated with interface management between fuel production, ADR power generation, and the electric power grid.

Predecisional - Official Use Only

Aerospace finds the quality and completeness of the cost basis of estimate is difficult to assess due to the age of the source data provided, but it is less mature than the MOX Fuel estimate. The ADR estimate also lacks costs associated with program-level risks that are likely to be encountered during development and operations. Therefore, the ADR program cost estimate reported in the 2014 PWG report may be low relative to realized actual costs should the program proceed. It is very likely that the ADR program would be subject to funding constraints on capital and construction.

Option 3 Immobilization

Both reports acknowledge the need to re-open discussions under the PMDA for use of the Immobilization option. Each notes uncertainty with can-in-canister and/or glass-in-canister technology, production processes, processing facilities, and production rate, and form for disposal in a geologic repository. Each notes that a geological repository has not been identified.

The Aerospace report notes that the Immobilization option cost estimate lacks costs associated with program-level risks that are likely to be encountered during development and operations. The immobilization cost estimate includes a range estimate to account for large cost uncertainty, however, the point estimate in the 2014 PWG report is reported at the lower end of the range. Therefore, the Immobilization Program cost estimate reported in the 2014 PWG report is low relative to what may be realized should the program proceed. It is likely that the Immobilization program would be subject to funding constraints on capital and construction.

One significant programmatic complexity for the Immobilization is the need to co-locate the plutonium with sufficient quantities of HLW to accomplish the immobilization mission. Neither of the two candidate locations discussed in the 2014 PWG report, SRS and Hanford WA, have both ingredients in sufficient quantities to accomplish the disposition mission by themselves. These constraints, combined with current policy and agreements between the DOE and the affected states, result in dependencies that render the Immobilization Option programmaticaly impractical.

Option 4 Downblend

Both reports acknowledge the need to re-open discussions under the PMDA for use of the Downblend option. Both assessments indicate that the Downblend option is lower in complexity and technical and programmatic risk compared to the other options, assuming the use of an existing geologically stable repository for disposition of the downblended material. Under this assumption, no new facilities or technology development are required for this option. Each report notes the need for engagement with Federal, State and local tribal representatives in the state of New Mexico, should WIPP be proposed as the disposal site. Each report notes that changes to the WIPP Land Withdrawal Act may be required, although further study is needed to fully specify the composition of the downblended material and the packaging configuration for this to be adequately understood.

The Aerospace report notes effects related to the suspension of operations at WIPP, the repository reference model used in this study.

Aerospace assesses the basis of estimate of the Downblend program cost-to-go to be adequate for concept level costing and consistent with industry best practices. Program level cost-risk associated with dependencies between the program elements is lower than that for MOX Fuel, ADR, and Immobilization, however, the Downblend program cost estimate in the 2014 PWG report may be low relative to actual costs, should the program proceed (see the companion report, "Plutonium Disposition Study Options Independent Assessment Phase 1 Report, Option 1: MOX Fuel, Option 4:

Predecisional - Official Use Only

Downblend,” April 13, 2015, TOR-2015-01848). The Downblend option cost is unlikely to be subject to impacts of annual funding constraints on capital improvements for processing plutonium.

Option 5: Borehole

Both reports acknowledge the need to re-open discussions under the PMDA for use of the Borehole option. Both assessments identify significant unknowns in site selection research and development, the lack of a well-posed concept and operational design, and challenges in establishing requirements for borehole disposal of plutonium.

The Aerospace report acknowledges the cost and schedule are unknown, and raises issues of site characterization, the need for permanent facilities and infrastructure, technology for drilling and emplacement, health and safety monitoring of the emplaced material, and retrievability requirements levied by current regulations that could prove difficult to meet.

Appendix A: Bibliography

1. Report of the Plutonium Disposition Working Group: Analysis of Surplus Weapon-Grade Plutonium Disposition Options, April 2014, Department of Energy
2. Plutonium Disposition Study Options Independent Assessment Phase 1 Report, Option 1: MOX Fuel, Option 4: Downblend, April 13, 2015, Aerospace Report # TOR-2015-01848
3. Advanced Disposition Reactor (ADR) Option Flow Diagram (Flow Diagram for Options.pdf), Predecisional, provided December 23, 2014, National Nuclear Security Administration
4. Immobilization Option Flow Diagram (Flow Diagram for Options.pdf), Predecisional, provided December 23, 2014, National Nuclear Security Administration
5. Deep Borehole (DBH) Option Flow Diagram (Flow Diagram for Options.pdf), Predecisional, December 23, 2014, National Nuclear Security Administration
6. MOX Fuel, Irradiation, Feedstock, and Transportation (MIFT) Lifecycle Costs for Plutonium Disposition- Downblend Option (MIFT Cost ADR option.pdf), Pre-Decisional Draft, April 2013, National Nuclear Security Administration
7. MOX Fuel, Irradiation, Feedstock, and Transportation (MIFT) Lifecycle Costs for Plutonium Disposition- Immobilization Option (MIFT Cost Immob option.pdf), Pre-Decisional Draft, April 2013, National Nuclear Security Administration
8. Preliminary Plutonium Disposition Options Analysis - Life Cycle Estimate (Point Estimate), Spreadsheet (SWM Rev 11-25-2013 PM Preliminary Main Options Analysis LCC Spread sheet Premaza 1956.xlsx), November 25, 2013, National Nuclear Security Administration
9. The Advanced Disposition Reactor Study: A Comprehensive Analysis of Plutonium Disposition Options Using Advanced Fast Reactors, Presentation (4 ADR_appBsummary_aerospacereview.pptx), January 14, 2015, Department of Energy Office of Nuclear Energy
10. Deep Borehole Disposal Concept and Deep Borehole Field Test, Presentation (5 Deep Borehole Disposal briefing 011415_.ppt), January 15, 2015, Department of Energy Office of Nuclear Energy
11. Advanced Disposition Reactor (ADR) Input, Presentation (ADR Aerospace.pptx), January 27, 2015, Savannah River Nuclear Solutions
12. ADR Layout, Drawing (UCNI_K ADR Layout.pdf), provided January 28, 2015, UCNI, Savannah River Nuclear Solutions
13. Alternative Option - Single Module Pool Type ADR, Spreadsheet (NE Excerpt From VP.xlsx), January 26, 2015, National Nuclear Security Administration Office of Acquisition and Project Management

Appendix B: Acronyms

ADR	Advanced Disposition Reactors
ALMR	Advanced Liquid Metal Reactor
ARIES	Advanced Recovery and Integrated Extraction System
\$B	Billion
CCO	Criticality Control Overpack
CD	Critical Decision
D&D	decommissioning, demolition
DBH	Deep Borehole
DMO	Direct Metal Oxide
DOE	Department of Energy
DOE-SR	DOE-Savannah River
DOT	Department of Transportation
DWPF	Defense Waste Processing Facility
EBR-II	Experimental Breeder Reactor-II
EM-HQ.	NNSA Office of Environmental Management
EPA	Environmental Protection Agency
FCI	Facility Condition Index
FFRDC	Federally Funded Research and Development Center
FFTF	Fast Flux Test Facility
FGE	Fissile Gram Equivalent
FMF	Fuel Manufacturing Facility
FY	Fiscal Year
GAO	Government Accountability Office
GSUR	Geologically Stable Underground Repository
HEU	Highly Enriched Uranium
HLW	High Level Waste
HM	Heavy Metal
HVAC	Heating, Ventilating, and Air Conditioning
IAEA	International Atomic Energy Agency
IG	Inspector General
INL	Idaho National Laboratory
ISFSI	Independent Spent Fuel Storage Installation
kg	Kilogram
KAFF	K-Area Fuel Fabrication Facility
KAMS	K-Area Material Storage
LANL	Los Alamos National Laboratory
LCCE	Lifecycle Cost Estimate
LWA	Land Withdrawal Act
LWRs	Light Water Reactors
\$M	Million
MIFT	MOX Fuel Irradiation, Feedstock, and Transportation Program
MFFF	Mixed Oxide Fuel Fabrication Facility
MOX	Mixed Oxide
MT	Metric Tons
NNSA	National Nuclear Security Administration
NRC	Nuclear Regulatory Commission

Predecisional - Official Use Only

ORR	Operational Readiness Review
PDCF	Pit Plutonium Disassembly and Conversion Facility
PDIP	Plutonium Disposition Infrastructure Program
PF-4	Plutonium Facility-4
PMDA	United States-Russia Plutonium Management and Disposition Agreement
PREP	Project Risk Evaluation Process
PRISM	Power Reactor Innovative Small Module
PRV	Plant Replacement Value
PWG	Plutonium Disposition Working Group
RY	Real Year
SBD	safeguards-by-design
SNL	Sandia National Laboratory
SRNS	Savannah River Nuclear Solutions
SRS	Savannah River Site
SSFP	Steady State Feedstock Project
TRU	Transuranic
WBS	Work Breakdown Structure
WIPP	Waste Isolation Pilot Plant
WSB	Waste Solidification Building
WTP	Waste Treatment and Immobilization Plant